

Platinum Resistance Temperature Detector

C 220

The C series thin-film PRTDs combine the ideal curve characteristics of ceramic wire-wound RTDs with the vibration resistance of glass wire-wound RTDs and represent an excellent alternative to wire-wound RTDs. They are characterized by high long-term stability, excellent temperature shock resistance and a wide temperature range of -196°C to +150°C. The deviation from the DIN EN 60751 (according to IEC 751) characteristic curve is minimal over the entire temperature range, they show no hysteresis. These features make them best suited for applications in aerospace, chemical and power generation plants and analytical equipment.

Nominal Resistance R_0	Tolerance	Order Number Plastic box
100 Ohm at 0°C	DIN EN 60751, class B	32 207 399

The measuring point for the nominal resistance is defined at 8 mm from the end of the sensor body.

Specification	DIN EN 60751
Nominal resistance	100 Ω at 0 °C
Temperature range	-196°C to +150°C
Temperature coefficient	TCR = 3850 ppm/K
Leads	AgPd
Long-term stability	tbd
Environmental conditions	unhoused for dry environments only
Vibration resistance	at least 40 g acceleration at 10 to 2000 Hz, depends on installation
Shock resistance	at least 100 g acceleration with 8ms half sine wave, depends on installation
Insulation resistance	> 100 M Ω at 150 °C
Self heating	0.4 K/mW at 0 °C
Response time	water current ($v = 0.4$ m/s): $t_{0.5} = 0.06$ s; $t_{0.9} = 0.20$ s air stream ($v = 2$ m/s): $t_{0.5} = 3.5$ s; $t_{0.9} = 13.0$ s
Measuring current	0.3 to 1.0 mA (self heating has to be considered)
Note	Other tolerances, values of resistance and wire lengths are available on request.

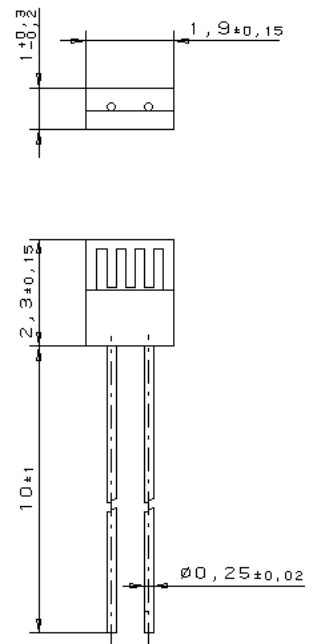

We reserve the right to make alterations and technical data printed. All technical data serves as a guideline and does not guarantee particular properties to any products.

Heraeus Sensor Technology GmbH, Reinhard-Heraeus-Ring 23, 63801 Kleinostheim, Germany
Phone: +49 (0) 6181/35-8098, Fax: +49 (0)6181/35-8101, E-Mail: info.HSND@Heraeus.com, Web:www.heraeus-sensor-technology.com