

# LFT level sensor - the all-round talent with TDR technology



	<p><b>Measuring range</b> <b>30 ... 1,990 mm</b></p> <p><b>TDR sensor</b></p>
--	---

the impulse is reflected there and runs along the probe back to the electronics, which then calculates the fill level from the time difference between the impulse sent out and the received on. The sensor can output this as continual measurement value (analogue output) as well as derive a freely positionable switching point [S] from it (switching output).

**Area of use**

Innovative TDR technology enables inexpensive, reliable fill level measurements largely independent of applications. The LFT is suitable both for continual fill level measurements and for limit-level detection in almost all fluids; changes in the properties of fluids to be measured do not influence it. It is the solution for precise and reliable measurements, especially in small tanks and containers – independent of installation conditions. Typical applications are, for example, in:

- Coolant lubricants
- Oil
- Other fuel types

Latest technology: TDR sensor with coaxial probe for continual fill level measurements with analogue and switching output, e.g., as alternative for capacitive sensors.

**Measurement principle**

The LFT uses the TDR technology (TDR = Time Domain Reflectometry) – a process for determining run times of electromagnetic waves. A low-energy, electromagnetic impulse is generated in the electronics of the sensor, coupled into the coaxial probe and run in the inside of this probe. When this impulse reaches the fluid on the surface to be measured, part of



## Dimensional drawing

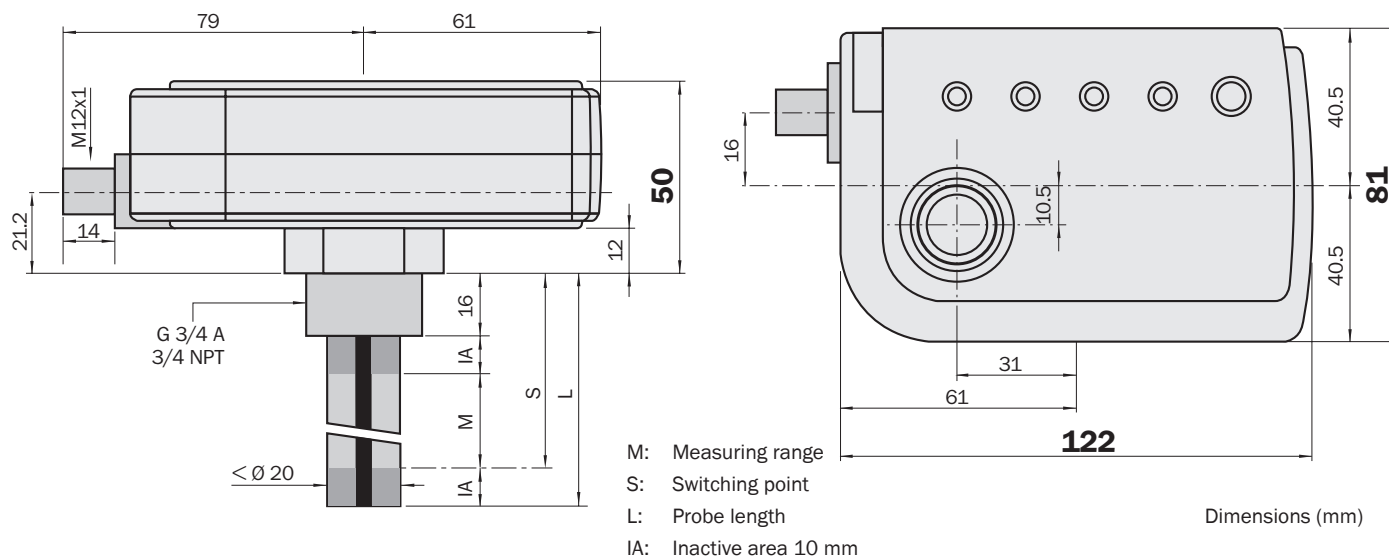

## Installation

The sensor is installed vertically from above into the container or tub using its connection thread screw. For example, it can be screwed in directly into a weld-in socket or a mounting bracket. Minimum bracket diameter and maximal bracket height do not apply here.

Install the sensor, so that it does not touch other tank installations (e.g., feed pipes or other measurement equipment), the container wall or the container bottom (the use of the supplied gasket with a height of 2 mm might be sufficient here). Minimum distances do not apply here.

Select the installation spot, so that the sensor is not exposed directly to filling. The sensor should not be installed in a calm area of the container, in which sediment could settle over time (e.g., sanding dust). Continual rinsing of the sensor via moving fluid is recommended.

## Operation

The sensor can be configured completely via the button. Visual feedback via the LEDs help here. You can make the following settings directly on the sensor:

- Set and delete the switching point [S] for the switching output and via Teach-in
- Switch between opener and closer for the switching output
- Set the measurement range
- Switch between voltage and current outputs for the analogue output
- Reset the sensor to the ex works state

Please read the operating instructions for a detailed explanation of operation

## Approvals

No special, application-related approvals are currently required for the sensor.

## Connection type

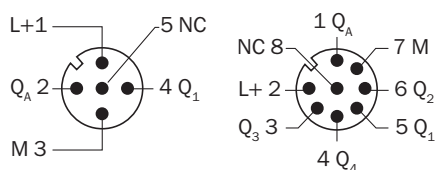

Pin	Male connector 5-pin	Wire colour cable terminal box	Male connector 8-pin	Wire colour cable terminal box
1	+U <sub>V</sub> (18 ... 30 V DC)	brown (brn)	Analogue output Q <sub>A</sub>	white (wht)
2	Analogue output Q <sub>A</sub>	white (wht)	+U <sub>V</sub> (18 ... 30 V DC)	brown (brn)
3	0 V	blue (blu)	Switching output Q3	green (grn)
4	Switching output Q1	black (blk)	Switching output Q4	yellow (yel)
5		not connect	Switching output Q1	gray (gra)
6			Switching output Q2	pink (pnk)
7			0 V	blue (blu)
8				not connect

**Technical data****Electric data**

Output functions Analogue output 4 ... 20 mA Namur  
and/or switching output PNP <sup>1)</sup>

**Analogue output**

burden by 4 ... 20 mA < 500 Ω  
Lower signal level 3.8 ... 4.0 mA  
Upper signal level 20 ... 20.5 mA  
Operating time 200 mS

**Switching output<sup>2)</sup>**

Signal voltage HIGH  $V_S - 2 V$   
Signal voltage LOW  $0 V \leq 1 V$   
Output current  $I_A$  < 200 mA

**Output load**

Capacitive load 100 nF  
Inductive load 1 H  
Operating time 200 ms

Supply voltage  $V_S$  <sup>3)</sup> 18 ... 30 V DC  
Residual ripple  $\leq 5 V_{SS}$   
Current consumption <sup>4)</sup> < 90 mA at 24 V DC  
Protection class  $\text{III}$   
Initialization time < 4 s  
Connection types Plug M12, 5-pin  
Plug M12, 8-pin

**Measurement performance<sup>5)</sup>**

Accuracy  $\pm 3 \text{ mm}$   
Reproducibility < 2 mm  
Resolution < 1 mm  
Hysteresis Switching output 3 mm or free adjustable  
Temperature drift 0.05 mm/K  
Measuring range [M] 30 ... 1,990 mm (at probe length 2,000 mm)  
Inactive area <sup>6)</sup> Each 10 mm

**Application conditions**

Dielectricity constant  $[\epsilon_r]$  <sup>7)</sup>  $\geq 1.8$  <sup>8)</sup>  
Conductivity <sup>7)</sup> No restrictions  
Temperature <sup>9)</sup> 0 ... +80 °C  
Ambient temperature <sup>9)</sup> Operation -10 ... +60 °C  
Storage -40 ... +80 °C  
Container pressure 1 bar rel. (during filling and emptying processes)  
Separating layer (e.g., oil on water) <sup>10)</sup> > 70 mm

**Mechanical data**

Enclosure rating IP 67  
Connection thread screw G 3/4" A; 3/4" NPT;  
Probe length [L] 100 ... 2,000 mm  
Material Housing PBT  
Probe 316L/1.4404  
Seal/probe end 1.4404/1.4310/PTFE

- <sup>1)</sup> Freely positionable in the complete measurement range  
<sup>2)</sup> Switching output short-circuit protected  
<sup>3)</sup> Connections reverse-polarity protected  
<sup>4)</sup> Without load  
<sup>5)</sup> Reference condition: Dielectricity constant  $[\epsilon_r] = 80$  (water) with changed  $\epsilon_r$ , measurement performance and the inactive range change

- <sup>6)</sup> At top and bottom plus tolerances of measurement accuracy  
<sup>7)</sup> Fluid to be measured  
<sup>8)</sup> Suitable for all oils, e.g., cutting, grinding and hydraulic oils, coolant lubricants, erosion dielectrics, cleaning and degreasing agents, all fluid lubricants, water and water-based fluids

- <sup>9)</sup> We recommend using a distance sleeve with simultaneous max. medium temperature and max. ambient temperature (see accessories).

- <sup>10)</sup> The sensor does not detect an oil layer of < 70 mm on water, i.e., the sensor detects the water level. Starting from an oil layer of > 70 mm, the complete fill level is detected, i.e., the level incl. the oil layer.

Type code	LFT										Optional					
					0	-	0									
<b>Probe length in mm (worth x 10)</b>																
From 100 mm	0	1	0													
To 2000 mm	2	0	0													
<b>Connection thread screw tank</b>																
G 3/4" A										1						
3/4" NPT										2						
<b>Connection housing</b>																
M12x1, 5-pin (max. 1 switching output possible)											A					
M12x1, 8-pin (min. 2 switching outputs)											B					
<b>Analogue output</b>																
Measurement value output (only with 4 switching outputs)												0				
Current output 4 ... 20 mA												1				
<b>Switching output</b>																
Opener													A			
Closer													B			
<b>Switching outputs/switching points (number)</b>																
1 Switching output, hysteresis locked, 3 mm															1	
2 Switching outputs, hysteresis locked, 3 mm															2	
4 Switching outputs, hysteresis locked, 3 mm															4	
1 Switching output, hysteresis adjustable															5	
2 Switching outputs, hysteresis adjustable															6	
<b>Optional: Device type</b>																
Customized factory settings															W	0 0

**Customized factory settings <sup>1)</sup>**

**Switching point hysteresis locked, (3 mm)**

Position switching point [S] (1-4)     mm

**Switching point, hysteresis adjustable**

Position of upper switching thresholds     mm  
[S] (1-4)

Position of lower switching thresholds     mm  
[S] (1-4)

**Analogue current output**

Upper value [20 mA]     mm

Lower value [4 mA]     mm

<sup>1)</sup> The sealing surface of the screw-in thread of the probe is the reference point for customer-specific setting (see dimensional drawing)

**Order information**

You can obtain the sensor pre-configured for your requirements by selecting the appropriate options in the order code.

**Default setting:**

- Measurement range [M] has the maximum extension between the inactive areas at the top and bottom (each 10 mm).
- The lower signal level of the analogue output (4 mA) is at the lower probe end, the upper signal level (20 mA) at the upper probe end.

## Order information \*

## Output: 1 current output (4 ... 20 mA) and 1 switching output/hysteresis: 3 mm

Type	Order no.	Probe length	Connection thread screw tank	Connection plug housing	Current output	Switching output Opener
LFT0200-01A1A10	1043593	200 mm	G 3/4" A	M12x1, 5-pin	4 ... 20 mA	1
LFT0300-01A1A10	1043594	300 mm	G 3/4" A	M12x1, 5-pin	4 ... 20 mA	1
LFT0400-01A1A10	1043595	400 mm	G 3/4" A	M12x1, 5-pin	4 ... 20 mA	1
LFT0500-01A1A10	1043596	500 mm	G 3/4" A	M12x1, 5-pin	4 ... 20 mA	1
LFT0600-01A1A10	1043597	600 mm	G 3/4" A	M12x1, 5-pin	4 ... 20 mA	1
LFT0700-01A1A10	1043598	700 mm	G 3/4" A	M12x1, 5-pin	4 ... 20 mA	1
LFT0800-01A1A10	1043599	800 mm	G 3/4" A	M12x1, 5-pin	4 ... 20 mA	1
LFT0900-01A1A10	1043600	900 mm	G 3/4" A	M12x1, 5-pin	4 ... 20 mA	1
LFT1000-01A1A10	1043601	1000 mm	G 3/4" A	M12x1, 5-pin	4 ... 20 mA	1
LFT1100-01A1A10	1043602	1100 mm	G 3/4" A	M12x1, 5-pin	4 ... 20 mA	1
LFT1200-01A1A10	1043603	1200 mm	G 3/4" A	M12x1, 5-pin	4 ... 20 mA	1
LFT1300-01A1A10	1043604	1300 mm	G 3/4" A	M12x1, 5-pin	4 ... 20 mA	1
LFT1400-01A1A10	1043605	1400 mm	G 3/4" A	M12x1, 5-pin	4 ... 20 mA	1
LFT1500-01A1A10	1043606	1500 mm	G 3/4" A	M12x1, 5-pin	4 ... 20 mA	1
LFT1600-01A1A10	1043607	1600 mm	G 3/4" A	M12x1, 5-pin	4 ... 20 mA	1
LFT1700-01A1A10	1043608	1700 mm	G 3/4" A	M12x1, 5-pin	4 ... 20 mA	1
LFT1800-01A1A10	1043609	1800 mm	G 3/4" A	M12x1, 5-pin	4 ... 20 mA	1
LFT1900-01A1A10	1043610	1900 mm	G 3/4" A	M12x1, 5-pin	4 ... 20 mA	1
LFT2000-01A1A10	1043611	2000 mm	G 3/4" A	M12x1, 5-pin	4 ... 20 mA	1

## Output: 4 switching output/hysteresis: 3 mm

Type	Order no.	Probe length	Connection thread screw tank	Connection plug housing	Current output	Switching output Opener
LFT0200-01B0A40	1043612	200 mm	G 3/4" A	M12x1, 8-pin	—	4
LFT0300-01B0A40	1043613	300 mm	G 3/4" A	M12x1, 8-pin	—	4
LFT0400-01B0A40	1043614	400 mm	G 3/4" A	M12x1, 8-pin	—	4
LFT0500-01B0A40	1043615	500 mm	G 3/4" A	M12x1, 8-pin	—	4
LFT0600-01B0A40	1043616	600 mm	G 3/4" A	M12x1, 8-pin	—	4
LFT0700-01B0A40	1043617	700 mm	G 3/4" A	M12x1, 8-pin	—	4
LFT0800-01B0A40	1043618	800 mm	G 3/4" A	M12x1, 8-pin	—	4
LFT0900-01B0A40	1043619	900 mm	G 3/4" A	M12x1, 8-pin	—	4
LFT1000-01B0A40	1043620	1000 mm	G 3/4" A	M12x1, 8-pin	—	4
LFT1100-01B0A40	1043621	1100 mm	G 3/4" A	M12x1, 8-pin	—	4
LFT1200-01B0A40	1043622	1200 mm	G 3/4" A	M12x1, 8-pin	—	4
LFT1300-01B0A40	1043623	1300 mm	G 3/4" A	M12x1, 8-pin	—	4
LFT1400-01B0A40	1043624	1400 mm	G 3/4" A	M12x1, 8-pin	—	4
LFT1500-01B0A40	1043625	1500 mm	G 3/4" A	M12x1, 8-pin	—	4
LFT1600-01B0A40	1043626	1600 mm	G 3/4" A	M12x1, 8-pin	—	4
LFT1700-01B0A40	1043627	1700 mm	G 3/4" A	M12x1, 8-pin	—	4
LFT1800-01B0A40	1043628	1800 mm	G 3/4" A	M12x1, 8-pin	—	4
LFT1900-01B0A40	1043629	1900 mm	G 3/4" A	M12x1, 8-pin	—	4
LFT2000-01B0A40	1043630	2000 mm	G 3/4" A	M12x1, 8-pin	—	4

\* Other models on request.

## Dimensional drawings and order information\*

Output: 1 current output (4 ... 20 mA) and 2 switching outputs/hysteresis: 3 mm

Type	Order no.	Probe length	Connection thread screw tank	Connection plug housing	Current output	Switching output Opener
LFT0200-01B1A20	1043631	200 mm	G 3/4" A	M12x1, 8-pin	4 ... 20 mA	2
LFT0300-01B1A20	1043632	300 mm	G 3/4" A	M12x1, 8-pin	4 ... 20 mA	2
LFT0400-01B1A20	1043633	400 mm	G 3/4" A	M12x1, 8-pin	4 ... 20 mA	2
LFT0500-01B1A20	1043634	500 mm	G 3/4" A	M12x1, 8-pin	4 ... 20 mA	2
LFT0600-01B1A20	1043635	600 mm	G 3/4" A	M12x1, 8-pin	4 ... 20 mA	2
LFT0700-01B1A20	1043636	700 mm	G 3/4" A	M12x1, 8-pin	4 ... 20 mA	2
LFT0800-01B1A20	1043637	800 mm	G 3/4" A	M12x1, 8-pin	4 ... 20 mA	2
LFT0900-01B1A20	1043638	900 mm	G 3/4" A	M12x1, 8-pin	4 ... 20 mA	2
LFT1000-01B1A20	1043639	1000 mm	G 3/4" A	M12x1, 8-pin	4 ... 20 mA	2
LFT1100-01B1A20	1043640	1100 mm	G 3/4" A	M12x1, 8-pin	4 ... 20 mA	2
LFT1200-01B1A20	1043641	1200 mm	G 3/4" A	M12x1, 8-pin	4 ... 20 mA	2
LFT1300-01B1A20	1043642	1300 mm	G 3/4" A	M12x1, 8-pin	4 ... 20 mA	2
LFT1400-01B1A20	1043643	1400 mm	G 3/4" A	M12x1, 8-pin	4 ... 20 mA	2
LFT1500-01B1A20	1043644	1500 mm	G 3/4" A	M12x1, 8-pin	4 ... 20 mA	2
LFT1600-01B1A20	1043645	1600 mm	G 3/4" A	M12x1, 8-pin	4 ... 20 mA	2
LFT1700-01B1A20	1043646	1700 mm	G 3/4" A	M12x1, 8-pin	4 ... 20 mA	2
LFT1800-01B1A20	1043647	1800 mm	G 3/4" A	M12x1, 8-pin	4 ... 20 mA	2
LFT1900-01B1A20	1043648	1900 mm	G 3/4" A	M12x1, 8-pin	4 ... 20 mA	2
LFT2000-01B1A20	1043649	2000 mm	G 3/4" A	M12x1, 8-pin	4 ... 20 mA	2

\* Other models on request.

## Cables and connectors

## SENSICK screw system M12, 5-pin, enclosure rating IP 67

## Female connector M12, 5-pin, straight

5 x 1,5 mm<sup>2</sup>, sheath PVC

Type	Order no.	Contacts	Cable length
DOL-1205-G02M	6008899	5	2 m
DOL-1205-G05M	6009868	5	5 m
DOL-1205-G10M	6010544	5	10 m

## Female connector M12, 5-pin, angled

5 x 1,5 mm<sup>2</sup>, sheath PVC

Type	Order no.	Contacts	Cable length
DOL-1205-W02MA	6008900	5	2 m
DOL-1205-W05MA	6009869	5	5 m
DOL-1205-W10MA	6010542	5	10 m

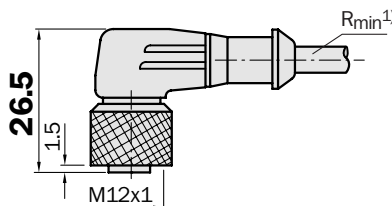
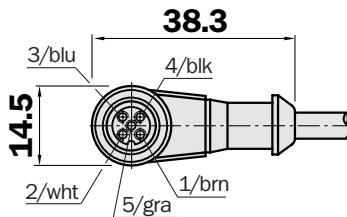
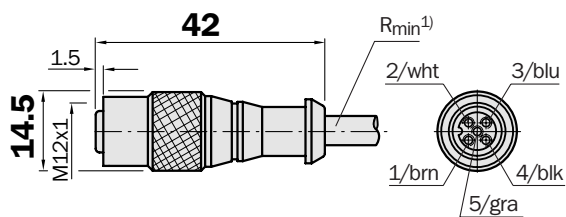

<sup>1)</sup> Minimum bend radius in dynamic use  
 $R_{min} = 20 \times \text{cable diameter}$

## Dimensional drawings and order information

## Connecting systems

## SENSICK screw-in system M12, 8-pin, enclosure rating IP 67

## Female connector M12, 8-pin, straight

8 x 1,5 mm<sup>2</sup>, sheath PVC

Type	Order no.	Contacts	Cable length
DOL-1208-G02M	6020633	8	2 m
DOL-1208-G05M	6020993	8	5 m
DOL-1208-G10M	6022152	8	10 m

## Female connector M12, 8-pin, angled

8 x 1,5 mm<sup>2</sup>, sheath PVC

Type	Order no.	Contacts	Cable length
DOL-1208-W02MA	6020992	8	2 m
DOL-1208-W05MA	6021033	8	5 m

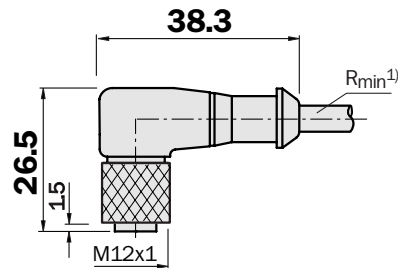
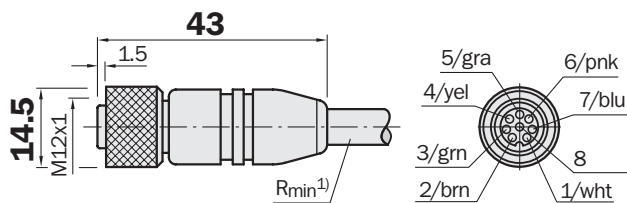

## Female connector M12, 5- or 8-pin, straight

5 x 1,5 mm<sup>2</sup> or 8 x 1,5 mm<sup>2</sup>, sheath PUR halogenfree

Type	Order no.	Contacts	Cable length
DOL-1205-G02MC	6025906	5	2 m
DOL-1205-G05MC	6025907	5	5 m
DOL-1205-G10MC	6025908	5	10 m
DOL-1208-G02MC	6035620	8	2 m
DOL-1208-G05MC	6035621	8	5 m
DOL-1208-G10MC	6035622	8	10 m

## Female connector M12, 5- or 8-pin, angled

5 x 1,5 mm<sup>2</sup> or 8 x 1,5 mm<sup>2</sup>, sheath PUR halogenfree

Type	Order no.	Contacts	Cable length
DOL-1205-W02MC	6025909	5	2 m
DOL-1205-W05MC	6025910	5	5 m
DOL-1205-W10MC	6025911	5	10 m
DOL-1208-W02MC	6035623	8	2 m
DOL-1208-W05MC	6035624	8	5 m
DOL-1208-W10MC	6035625	8	10 m

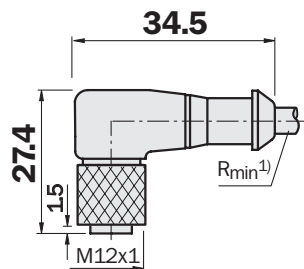
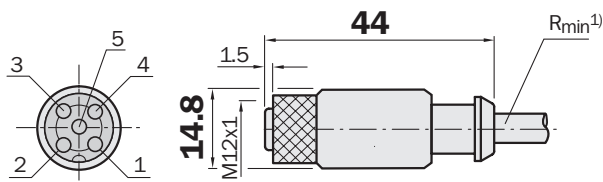

<sup>1)</sup> Minimum bend radius in dynamic use  
 $R_{min} = 20 \times \text{cable diameter}$

## Power supply, 100 ... 240 V AC/24 V DC, 21 A, IP 20

Type	Order no.
Power supply	7028789

## Counter-nut

Type	Price
3,4"G, PA	on request
3,4"NPT, PA	on request

## Distance sleeve

Type	Price
3,4"G, stainless steel	on request
3,4"G, plastic	on request
3,4"NPT, stainless steel	on request
3,4"NPT, plastic	on request

**Australia**

Phone +61 3 9497 4100  
1800 33 48 02 – tollfree  
E-Mail sales@sick.com.au

**Belgium/Luxembourg**

Phone +32 (0)2 466 55 66  
E-Mail info@sick.be

**Brasil**

Phone +55 11 3215-4900  
E-Mail sac@sick.com.br

**Ceská Republika**

Phone +420 2 57 91 18 50  
E-Mail sick@sick.cz

**China**

Phone +852-2763 6966  
E-Mail ghk@sick.com.hk

**Danmark**

Phone +45 45 82 64 00  
E-Mail sick@sick.dk

**Deutschland**

Phone +49 211 5301-250  
E-Mail info@sick.de

**España**

Phone +34 93 480 31 00  
E-Mail info@sick.es

**France**

Phone +33 1 64 62 35 00  
E-Mail info@sick.fr

**Great Britain**

Phone +44 (0)1727 831121  
E-Mail info@sick.co.uk

**India**

Phone +91-22-4033 8333  
E-Mail info@sick-india.com

**Israel**

Phone +972-4-999-0590  
E-Mail info@sick-sensors.com

**Italia**

Phone +39 02 27 43 41  
E-Mail info@sick.it

**Japan**

Phone +81 (0)3 3358 1341  
E-Mail support@sick.jp

**Nederlands**

Phone +31 (0)30 229 25 44  
E-Mail info@sick.nl

**Norge**

Phone +47 67 81 50 00  
E-Mail austefjord@sick.no

**Österreich**

Phone +43 (0)22 36 62 28 8-0  
E-Mail office@sick.at

**Polska**

Phone +48 22 837 40 50  
E-Mail info@sick.pl

**Republic of Korea**

Phone +82-2 786 6321/4  
E-Mail kang@sickkorea.net

**Republika Slovenija**

Phone +386 (0)1-47 69 990  
E-Mail office@sick.si

**România**

Phone +40 356 171 120  
E-Mail office@sick.ro

**Russia**

Phone +7 495 775 05 34  
E-Mail info@sick-automation.ru

**Schweiz**

Phone +41 41 619 29 39  
E-Mail contact@sick.ch

**Singapore**

Phone +65 6744 3732  
E-Mail admin@sicksgp.com.sg

**Suomi**

Phone +358-9-25 15 800  
E-Mail sick@sick.fi

**Sverige**

Phone +46 10 110 10 00  
E-Mail info@sick.se

**Taiwan**

Phone +886 2 2365-6292  
E-Mail sickgrc@ms6.hinet.net

**Türkiye**

Phone +90 216 587 74 00  
E-Mail info@sick.com.tr

**USA/Canada/México**

Phone +1(952) 941-6780  
1 800-325-7425 – tollfree  
E-Mail info@sickusa.com

More representatives and agencies  
in all major industrial nations at  
[www.sick.com](http://www.sick.com)