

TECHNICAL DATA

MQ-138 GAS SENSOR

FEATURES

Wide detecting scope
Stable and long life

Fast response and High sensitivity
Simple drive circuit

APPLICATION

They are used in Breath alcohol detector, solvent detectors ,Air quality control equipments for buildings/offices, are suitable for detecting of n-Hexane, Benzene, NH₃, alcohol, ,smoke, CO ,etc.

SPECIFICATIONS

A. Standard work condition

Symbol	Parameter name	Technical condition	Remarks
V _c	Circuit voltage	5V±0.1	AC OR DC
V _H	Heating voltage	5V±0.1	ACOR DC
R _L	Load resistance	can adjust	
R _H	Heater resistance	31 ± 3	Room Tem
P _H	Heating consumption	less than 850mw	

B. Environment condition

Symbol	Parameter name	Technical condition	Remarks
Tao	Using Tem	-10 -45	
Tas	Storage Tem	-20 -70	
R _H	Related humidity	less than 95%Rh	
O ₂	Oxygen concentration	21%(standard condition)Oxygen concentration can affect sensitivity	minimum value is over 2%

C. Sensitivity characteristic

Symbol	Parameter name	Technical parameter	Remarks
R _s	Sensing Resistance	20K -200K (1000ppm Benzene)	Detecting concentration scope : 10ppm -1000ppm Benzene 10ppm -1000ppm Alcohol 10ppm -3000ppm NH ₃
(200/50) NH ₃	Concentration Slope rate	0.65	
Standard Detecting Condition	Temp: 20 ±2 Humidity: 65%±5%	V _c :5V±0.1 V _H : 5V±0.1	
Preheat time	Over 24 hours		

D. Structure and configuration, basic measuring circuit

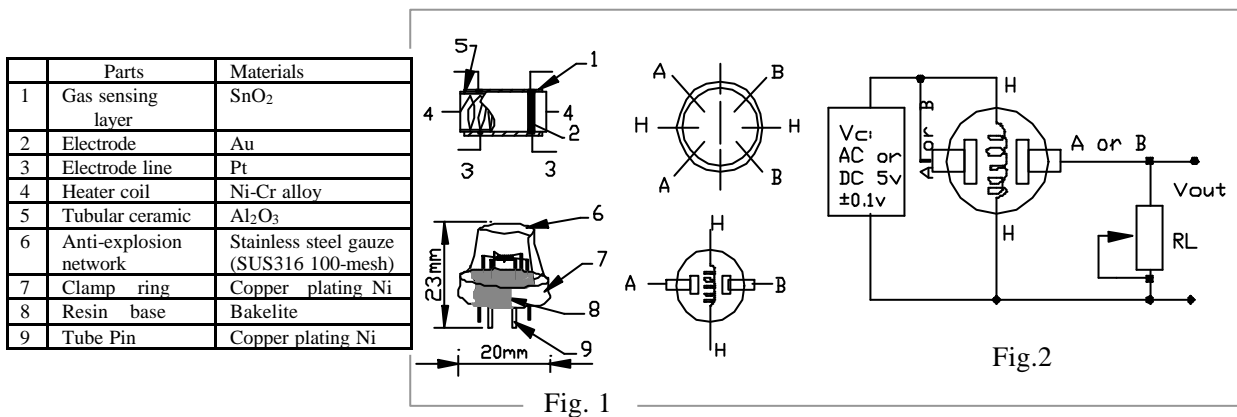

Structure and configuration of MQ-138 gas sensor is shown as Fig. 1 (Configuration A or B), sensor composed by micro AL₂O₃ ceramic tube, Tin Dioxide (SnO₂) sensitive layer, measuring electrode and

heater are fixed into a crust made by plastic and stainless steel net. The heater provides necessary work conditions for work of sensitive components. The enveloped MQ-138 have 6 pin ,4 of them are used to fetch signals, and other 2 are used for providing heating current.

Electric parameter measurement circuit is shown as Fig.2

E. Sensitivity characteristic curve

Fig.2 sensitivity characteristics of the MQ-138

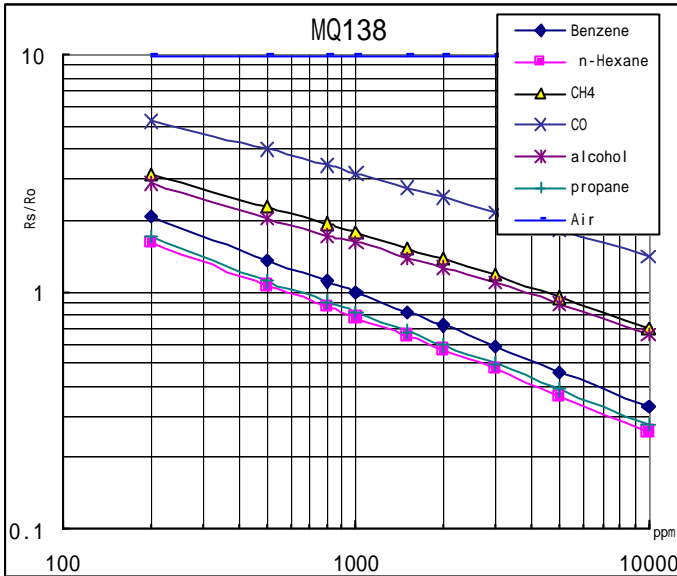

Fig.3 is shows the typical sensitivity characteristics of the MQ-138 for several gases.

in their: Temp: 20 °C, Humidity: 65%, O₂ concentration 21% RL=20k

Ro: sensor resistance at 1000ppm of Benzene in the clean air. Rs: sensor resistance at various concentrations of gases.

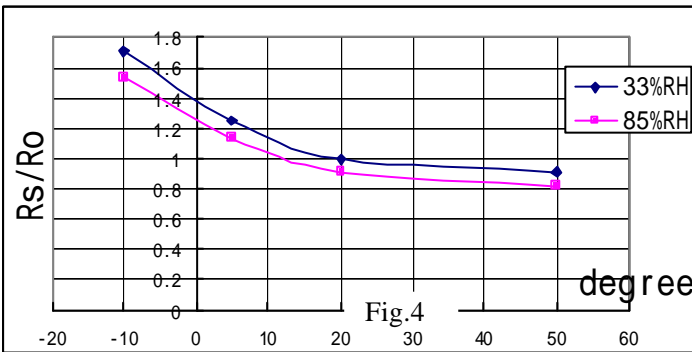

Fig.4 is shows the typical dependence of the MQ-138 on temperature and humidity.

Ro: sensor resistance at 1000ppm of Benzene in air at 33%RH and 20 degree. Rs: sensor resistance at 1000ppm of Benzene at different temperatures and humidity

SENSITIVITY ADJUSTMENT

.Resistance value of MQ-138 is difference to various kinds and various concentration gases. So, When using this components, sensitivity adjustment is very necessary. we recommend that you calibrate the detector for 100ppm Benzene or Alcohol concentration in air and use value of Load resistance that(R_L) about 47 K (20K to 100 K).

When accurately measuring, the proper alarm point for the gas detector should be determined after considering the temperature and humidity influence.

