

# Altimeter / Barometer Module SMD500

## ultra low power, low voltage

Bosch Sensortec



**BOSCH**  
Invented for life

### 1. General Description

The SMD500 marks a new generation of high precision digital pressure sensors for consumer applications.

Its ultra low-power, low voltage electronics are optimized for use in mobile phones, PDAs, GPS devices and outdoor equipment. With an altitude noise down to 0.25 m it offers superior performance. The I<sup>2</sup>C interface allows for easy system integration with a micro-controller.

Robert Bosch is the world market leader for pressure sensors in automotive applications. Based on the experience of over 100 million pressure sensors in the field, the SMD500 opens a new generation of micro-machined pressure sensors.

### Typical Applications

- ▶ Outdoor navigation
- ▶ Dead reckoning
- ▶ Leisure and sports
- ▶ Weather forecast
- ▶ Vertical velocity indication (rise / sink speed)
- ▶ Security systems

The SMD500 is based on piezoresistive technology for EMC robustness, high accuracy and linearity as well as long term stability.

### Altimeter / Barometer SMD500

#### Key Features

▶ Pressure range	300 ... 1100 hPa (+9000 ... -500 m)
▶ Supply voltage	2.0 ... 3.6 V
▶ Current consumption	3 $\mu$ A (std. avg. @ 1 sample / sec.) 8 $\mu$ A (high resolution)
▶ Resolution (rms noise)	0.06 hPa (0.5 m) std. resolution 0.03 hPa (0.25 m) high resolution
▶ Sigma delta ADC	
▶ Fully calibrated	
▶ Temperature measurement included	
▶ Digital two wire I <sup>2</sup> C interface	
▶ Lead free and RoHS compliant	

### Altitude above Sea Level vs. Barometric Pressure

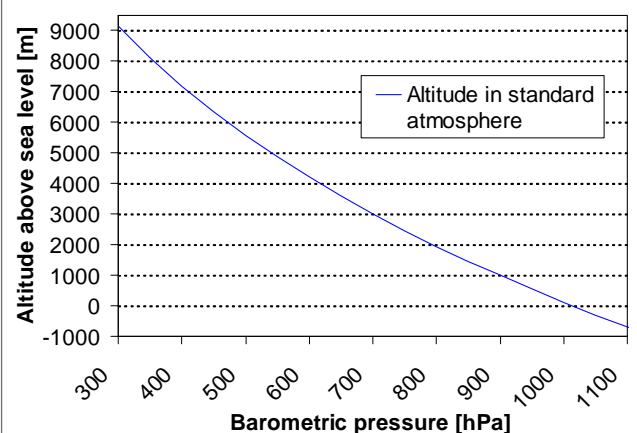

Absolute Maximum Ratings	
Storage temperature	-55 ... +125 °C
Supply voltage	-0.3 ... 6.0 V
ESD Rating (HBM)	±2 kV
Overpressure	5000 hPa

Operating Conditions	
Temperature, operational	-40 ... +85 °C
full accuracy	-20 ... +60 °C
Supply voltage VDD	2.0 ... 3.6 V; typ 3.3 V
Standby current	0.1 µA typ.
Avg. current consumption @ 1Hz data refresh rate	3 µA typ. standard mode 8 µA typ. high res. mode
Pressure range	300 ... 1100 hPa
RMS noise expressed in pressure	0.06 hPa typ. standard 0.03 hPa typ. high res.
RMS noise expressed in altitude (@ 1 conversion)	0.5 m typ. standard 0.25 m typ. high res.
Absolute accuracy @ p = 300 ... 1100 hPa, -20 ... +60°C, VDD = 3.3 V, MCLK = 32768 Hz	pressure: 1.5 hPa typ. temperature: 1°C typ.
Serial data clock	max. 400 kHz
Master clock frequency (selectable)	32768 Hz ± 3 % or 1 MHz ± 3 %
Pressure conversion time	34 ms @ 32768 Hz

The SMD500 is designed to be connected directly to a microcontroller of a mobile device via the I<sup>2</sup>C bus.

The pressure and temperature data comes as 16 bit each and has to be compensated by the calibration data of the PROM of the SMD500.

## SMD500 pinout configuration

Top view LCC8 ceramic package  
dimensions: 5.0 x 5.0 (± 0.2) x 1.6 mm<sup>3</sup> (± 0.15).

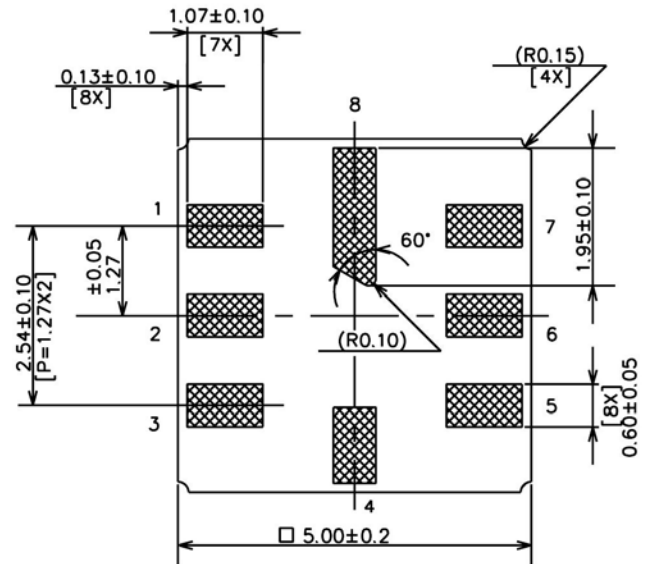

Pinout		
1	GND	ground
2	NC	do not connect
3	VDDD	power supply digital
4	VDDA	power supply analog
5	MCLK	master clock input
6	SCL	I <sup>2</sup> C serial bus clock input
7	SDA	I <sup>2</sup> C serial bus data
8	XCLR	master clear (low active) input

## 2. General Function and application schematics

The SMD500 consists of a piezoresistive sensor, an analog to digital converter, control unit with PROM and a serial I<sup>2</sup>C interface. The SMD500 converts the uncompensated value of pressure and temperature from the pressure sensor and has stored 64 bit of individual calibration data in a PROM. This calibration data is used to compensate offset, temperature dependence etc. of the sensor.

- pressure data word (16 bit word, 16 bit resolution) UP
- temperature data word (16 bit word, 13 bit resolution) UT

The SMD500 is designed to be connected directly to a microcontroller of a mobile device via the I<sup>2</sup>C interface.

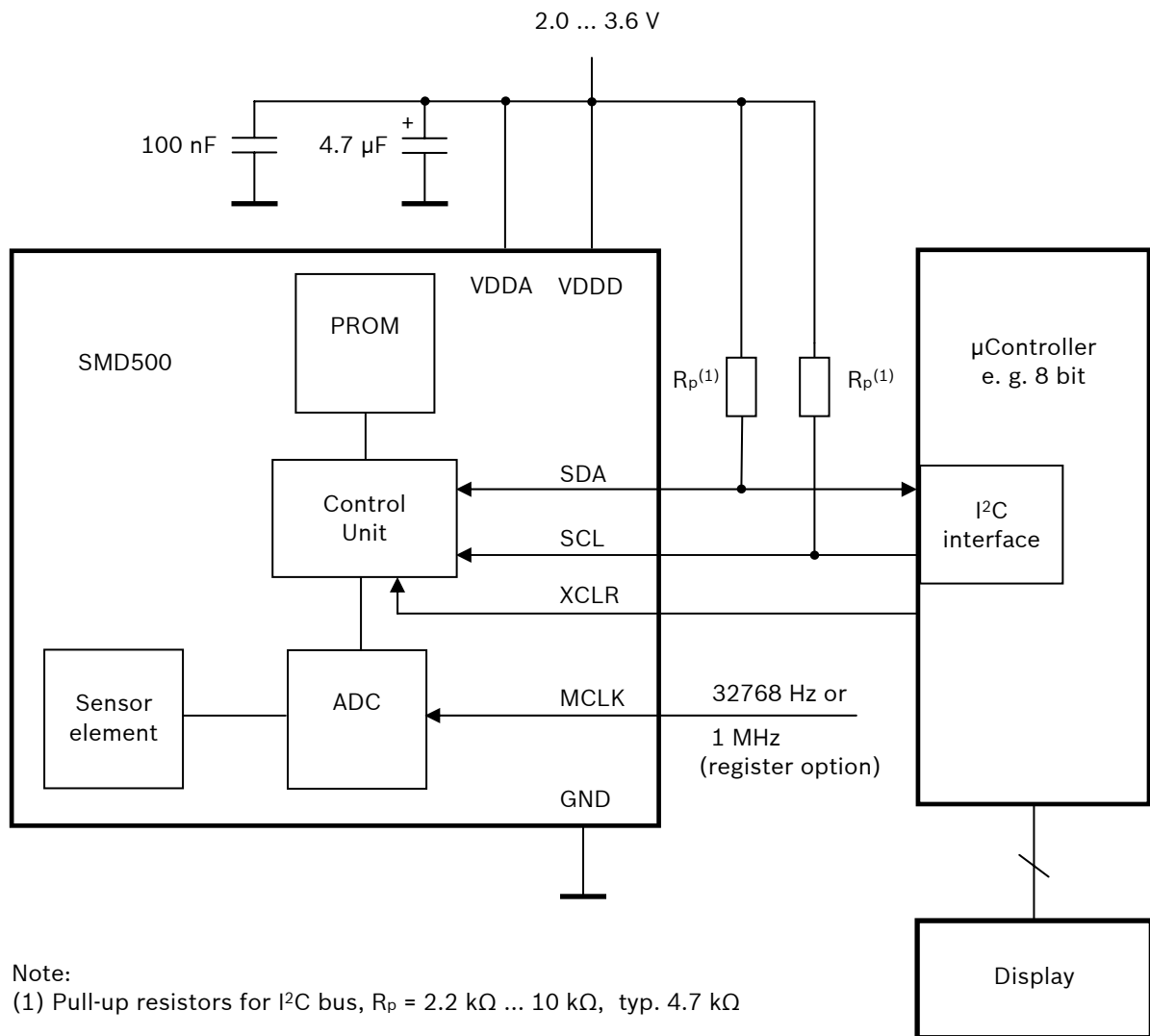

Figure 1: Typical application circuit

To guarantee conversion accuracy two supply voltage decoupling capacitors of  $4.7 \mu\text{F}$  and  $100 \text{ nF}$  should be placed between VDD and GND of the SMD500.

### 3. Measurement of pressure and temperature

The steps to measure pressure and temperature data and calculation of the physical values are shown in the following figures. For all calculations presented here an ANSI C code is available.

To start a pressure or temperature measurement the microcontroller sends a start sequence. After the conversion time the result value (UT or UP) can be read via the I<sup>2</sup>C interface. For calculating the temperature in °C and pressure in hPa the calibration data is used. These constants can be read out from the SMD500 PROM via the I<sup>2</sup>C interface once at software start-up.

The sampling rate can be increased up to 25 samples per second for dynamic measurement or to average out noise. In this case, it is sufficient to measure the temperature only once per second and use this value for all pressure measurements in this period. Using oversampling and averaging, the optimum compromise between power consumption, speed and resolution can be selected, see table 1.

Table 1: Relation between averaging, power consumption, speed and resolution (at sea level).

mode	pressure measurements per sec	number of averages	temperature measurements per sec	data refresh rate [Hz]	avg. current consumption [μA]	RMS noise [hPa]	RMS noise [m]
standard	1	1	1	1	3	0.06	0.5
high resolution	4	4	1	1	8	0.03	0.25
high speed	10	1	1	10	20	0.06	0.5

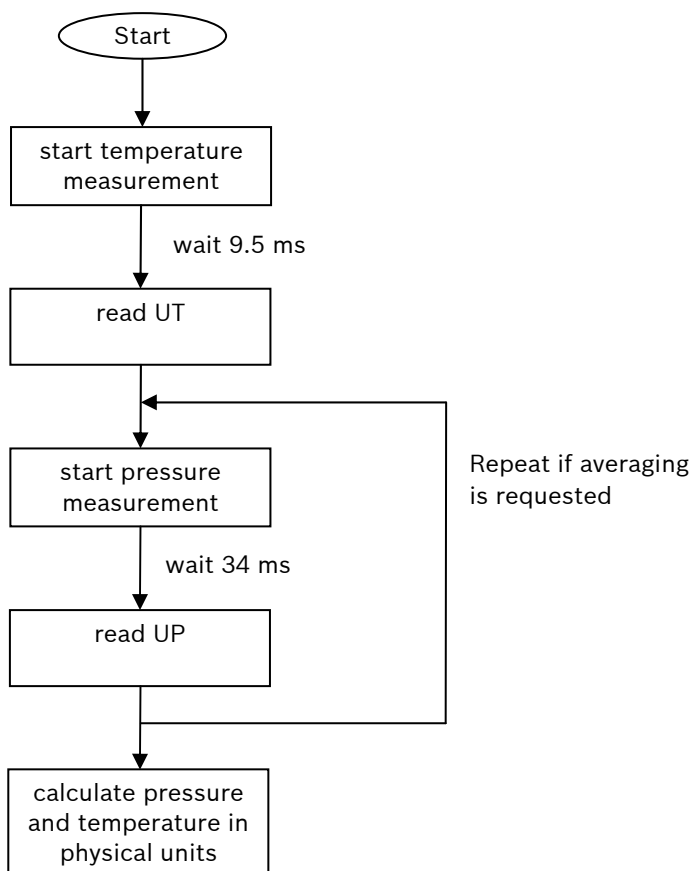

Figure 2: Flow chart temperature and pressure measurement

### 3.1. Calibration coefficients

The 64 bit PROM is partitioned in four words F1 to F4 of 16 bit each. These 64 bits contain six calibration coefficients AC1 to AC6 as shown in table 2. Each sensor module has individual coefficients. Before the first calculation of temperature and pressure, the master reads out the PROM data words F1 to F4 and converts them into the six calibration coefficients AC1 to AC6. This corresponds to the C code functions SMD500\_convertPROMdata.

Then the function SMD500\_init\_calB1B2 calculates the two derived coefficients B1 and B2 as shown in figure 3.

Table 2: PROM mapping of the six coefficients AC1 to AC6

	bit 15	bit 14	bit 13	bit 12	bit 11	bit 10	bit 9	bit 8	bit 7	bit 6	bit 5	bit 4	bit 3	bit 2	bit 1	bit 0
F1	AC2_1	AC2_0	AC1_13	AC1_12	AC1_11	AC1_10	AC1_9	AC1_8	AC1_7	AC1_6	AC1_5	AC1_4	AC1_3	AC1_2	AC1_1	AC1_0
F2	AC2_8	AC2_7	AC2_6	AC2_5	AC2_4	AC2_3	AC2_2	AC3_8	AC3_7	AC3_6	AC3_5	AC3_4	AC3_3	AC3_2	AC3_1	AC3_0
F3	AC5_2	AC5_1	AC5_0	AC4_12	AC4_11	AC4_10	AC4_9	AC4_8	AC4_7	AC4_6	AC4_5	AC4_4	AC4_3	AC4_2	AC4_1	AC4_0
F4	AC5_6	AC5_5	AC5_4	AC5_3	AC6_11	AC6_10	AC6_9	AC6_8	AC6_7	AC6_6	AC6_5	AC6_4	AC6_3	AC6_2	AC6_1	AC6_0

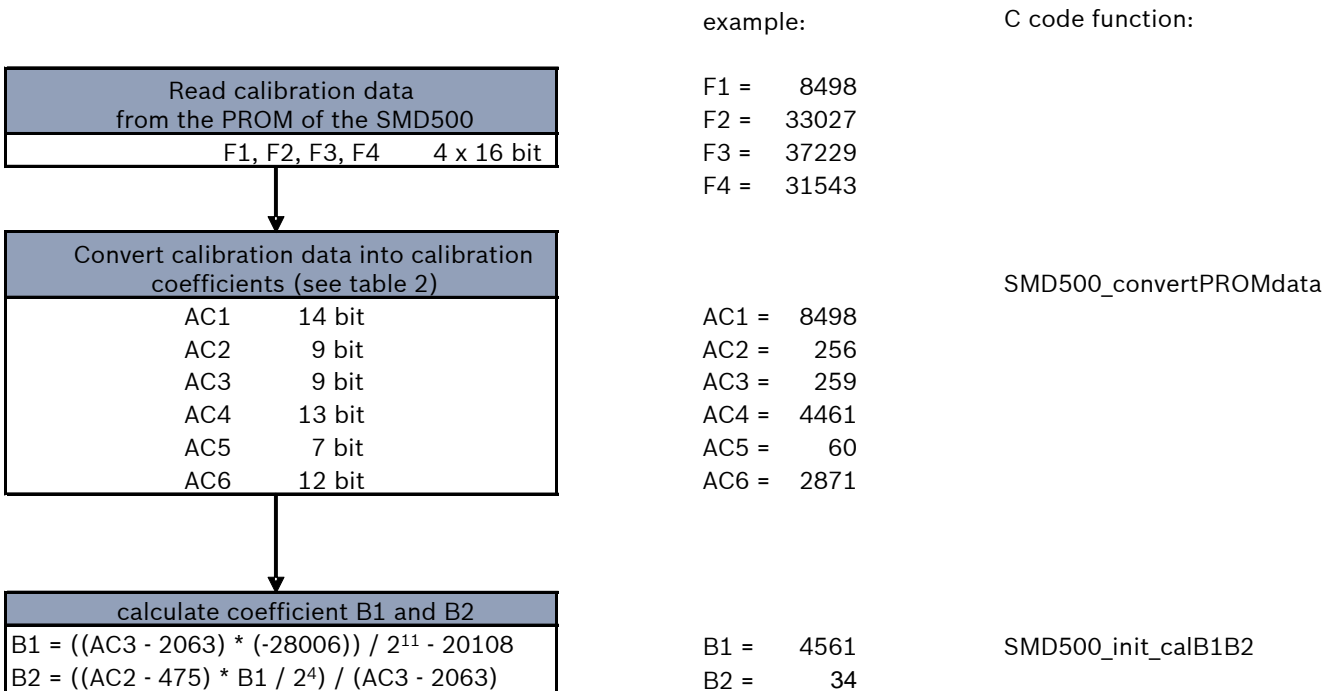
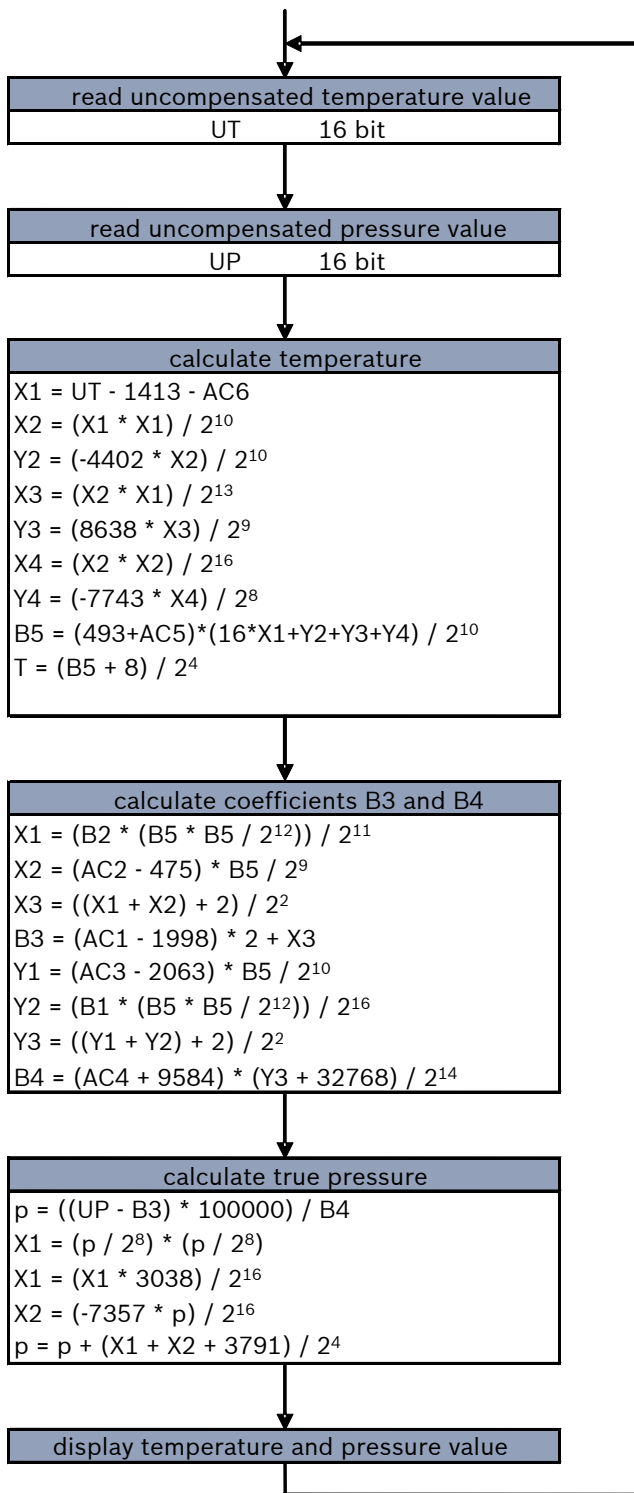

Figure 3: Initial calculations for the SMD500

### 3.2. Calculating pressure and temperature

The calculation of temperature in °C and pressure in Pa is shown in figure 4. This corresponds to the C code functions SMD500\_caltemperature, SMD500\_calB3, SMD500\_calB4 and SMD500\_calpressure.



example:

UT = 4826

UP = 38585

B5 = 4165

T = 261

= 26.1 °C

B3 = 12572

B4 = 26580

p = 97839

= 978.39 hPa

C code function:

SMD500\_caltemperature

SMD500\_calB3B4

SMD500\_calpressure

Figure 4: Calculation temperature and pressure

The calculated true pressure is given in steps of 1 Pa and the temperature in steps of 0.1 °C.

### 3.3 Calculating altitude

With the calculated pressure  $p$  and the pressure at sea level  $p_0$  e.g. 1013.25 hPa, the altitude in meters can be calculated with the international barometric formula using:

$$\text{altitude} = 44330 * \left( 1 - \left( \frac{p}{p_0} \right)^{5.255} \right)$$

$\Delta p = 1$  hPa corresponds to 8.43 m at sea level

## 4. Serial Interface

The SMD500 has an I<sup>2</sup>C bus interface comprising of serial clock (SCL) and serial data (SDA). SDA and SCL have open-drain outputs, so an external pull-up resistor is required, typical 4.7 kΩ. For more information see I<sup>2</sup>C protocol specification. The I<sup>2</sup>C bus is used to control the sensor, read calibration data from the PROM and to read the measured results when A/D conversion is finished.

The digital interface also includes master clock (MCLK) input and master clear (XCLR) input. The MCLK signal needs to be clocked during the conversion period. It can be stopped after the A/D conversion has been finished. MCLK can also run continuously.

XCLR is used to reset the A/D converter. Reset initializes internal registers and counters. The device is automatically reset by power on reset (POR) circuitry. If the supply voltage rise time is longer than 400 ns, it is required to reset the device with XCLR reset. If the supply voltage rise time is shorter, the XCLR reset is not necessary.

### 4.1 Device and register address

The I<sup>2</sup>C bus standard makes it possible to connect several I<sup>2</sup>C bus devices into the same bus. The SMD500 module address is shown below. The LSB of the device address distinguishes between read (1) and write (0) operation.

Table 3: SMD500 device address

A	A	A	A	A	A	A	W/ R
7	6	5	4	3	2	1	
1	1	1	0	1	1	1	0/1

### 4.2 Definition I<sup>2</sup>C protocol

The I<sup>2</sup>C interface definition has special bus signal conditions. Figure 5 shows start (S), stop (P) and binary data conditions. At start condition SCL is high and SDA has a falling edge. Then the slave address is sent. After the 7 address bits the direction control bit R/W selects read or write operation. When a slave device recognizes it is being addressed, it should acknowledge by pulling SDA low in the ninth SCL (ACK) cycle. At stop condition SCL is also high but SDA has a rising edge. Data must be held stable at SDA when SCL is high. Data can change value at SDA only when SCL is low.

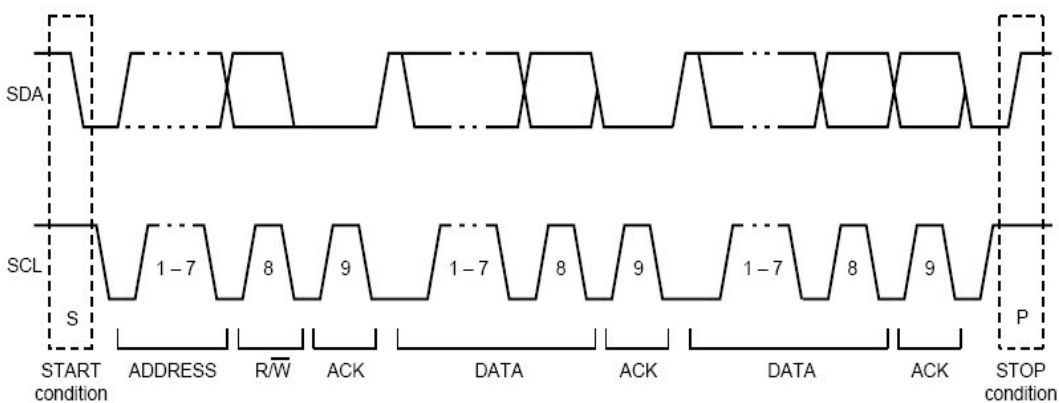

Figure 5: I<sup>2</sup>C Interface protocol definition

### 4.3 Starting temperature and pressure measurement

Figure 6 and 7 show the timing diagrams to start the measurement of the temperature value UT and pressure value UP. After start condition the master sends the module address write, the register address and the control register. The SMD500 sends an acknowledgement (ACKS) every 8 data bits when data is received. The master sends a stop condition after the last ACKS.

#### Clock Frequency selection:

Bit 2 of the control register selects the master clock prescaler, see table 4. When the bit is low, the external clock signal 32768 kHz is divided by two and the internal frequency will be 16384 Hz. If the master clock selection bit is high, the external clock 1 MHz is divided by 64 and the internal clock frequency will be 15625 Hz. The conversion times for external clock 1 MHz and 32768 Hz are 34 ms for the pressure measurement and 9.5 ms for temperature measurement.

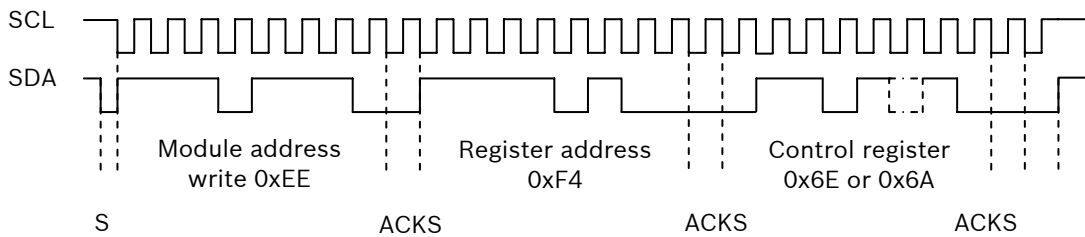

Figure 6: Timing diagram for starting temperature measurement

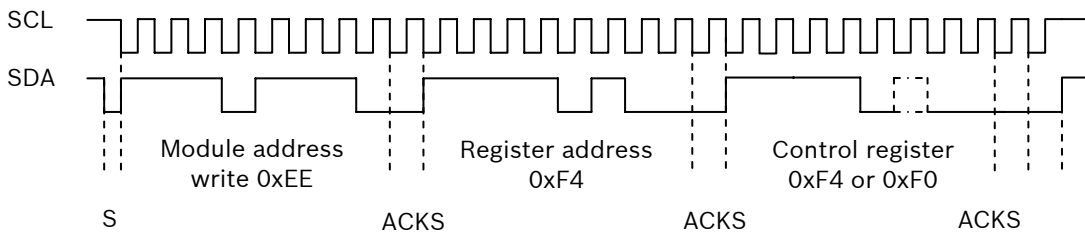

Figure 7: Timing diagram for starting pressure measurement

#### Abbreviations:

S	Start
P	Stop
ACKS	Acknowledge by Slave
ACKM	Acknowledge by Master
NACKM	Not Acknowledge by Master

Table 4: Control register values

measurement	Master clock	control register value	conversion time
temperature	32.768 kHz	0x6E	9.5 ms
	1 MHz	0x6A	9.5 ms
pressure	32.768 kHz	0xF4	34 ms
	1 MHz	0xF0	34 ms



#### 4.4 Read A/D conversion result or PROM data

Figure 8 shows the timing diagram to read out the temperature data word UT (16 bit), the pressure data word UP (16 bit) and the PROM data register F1 to F4 (16 bit each).

After the start condition the master sends the module address write command and register address. The register address selects the read register:

Temperature or pressure value UT or UP	0xF6
PROM data register F1	0xF8
PROM data register F2	0xFA
PROM data register F3	0xFC
PROM data register F4	0xFE

Then a restart condition needs to be sent by the master followed by the module address read that will be acknowledged by the SMD500 (ACKS). It sends first the 8 MSB, acknowledged by the master (ACKM), then the 8 LSB. The master sends a not acknowledge (NACKM) and finally a stop condition.

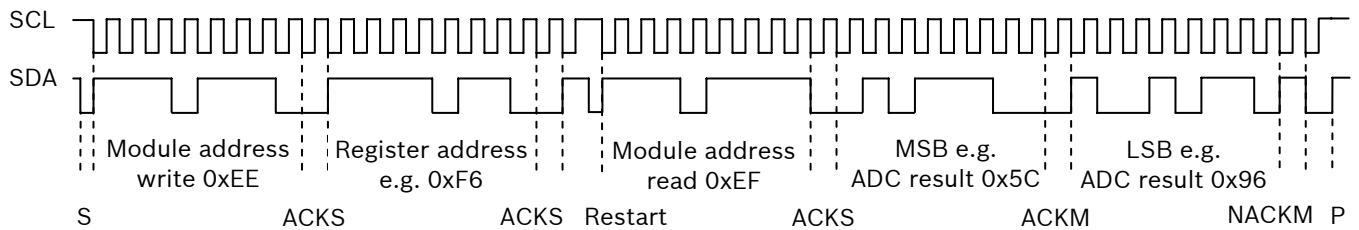

Figure 8: Timing diagram read A/D conversion result

Bosch Sensortec is a newly founded subsidiary of Bosch. It focuses on application and marketing of micromechanical components for all markets except the automotive.

Please contact us for further details.

**Bosch Sensortec GmbH**  
 Gerhard-Kindler-Strasse 8  
 72770 Reutlingen, Germany

Leopold.Beer@bosch-sensortec.com  
[www.bosch-sensortec.com](http://www.bosch-sensortec.com)  
 Modifications reserved | Printed in Germany  
 Version\_1.2\_062006 – sensor data may be subject to change before final release