

# W 9-2: A Versatile, Complete and Compact Series

	<b>Photoelectric proximity switches BGS</b>
	<b>Photoelectric proximity switches ener.</b>
	<b>Photoelectric proximity switches V</b>



	<b>Photoelectric reflex switches</b>
	<b>Through-beam photoelectric switches</b>

Depending on the job, the most suitable sensor can be selected from the W 9-2 series.

Overview of the sensors:

- WT 9-2, with adjustable background suppression, max. scanning distance 250 mm,
- WT 9-2, energetic, max. scanning distance 450 mm,
- WT 9-2, V model, max. scanning distance 20 mm,
- WL 9-2, basic model, max. scanning range 4 m,
- WL 9-2, Teach-in model, max. scanning range 4 m,
- WL 9-2, focus, max. scanning range 0.4 m,
- WS/WE 9-2, max. scanning range 7 m.

There are multifaceted applications in the targeted main branches thanks to this great variety of products:

- Storage and handling engineering,
- Packaging industry,
- Electronics industry,
- Elevator construction.

The W 9-2 series is as versatile as the tasks in automation.

The standardized, compact housing model makes it possible to use high-performance sensors that operate reliably even in cramped mounting conditions. All W 9-2 models have red light transmitters as a standard feature. The sensor can be aligned on the object quickly and precisely using the visible light spot. In the models with Teach-in function, the sensor optimizes its sensitivity automatically to the given operating conditions at the push of a button.

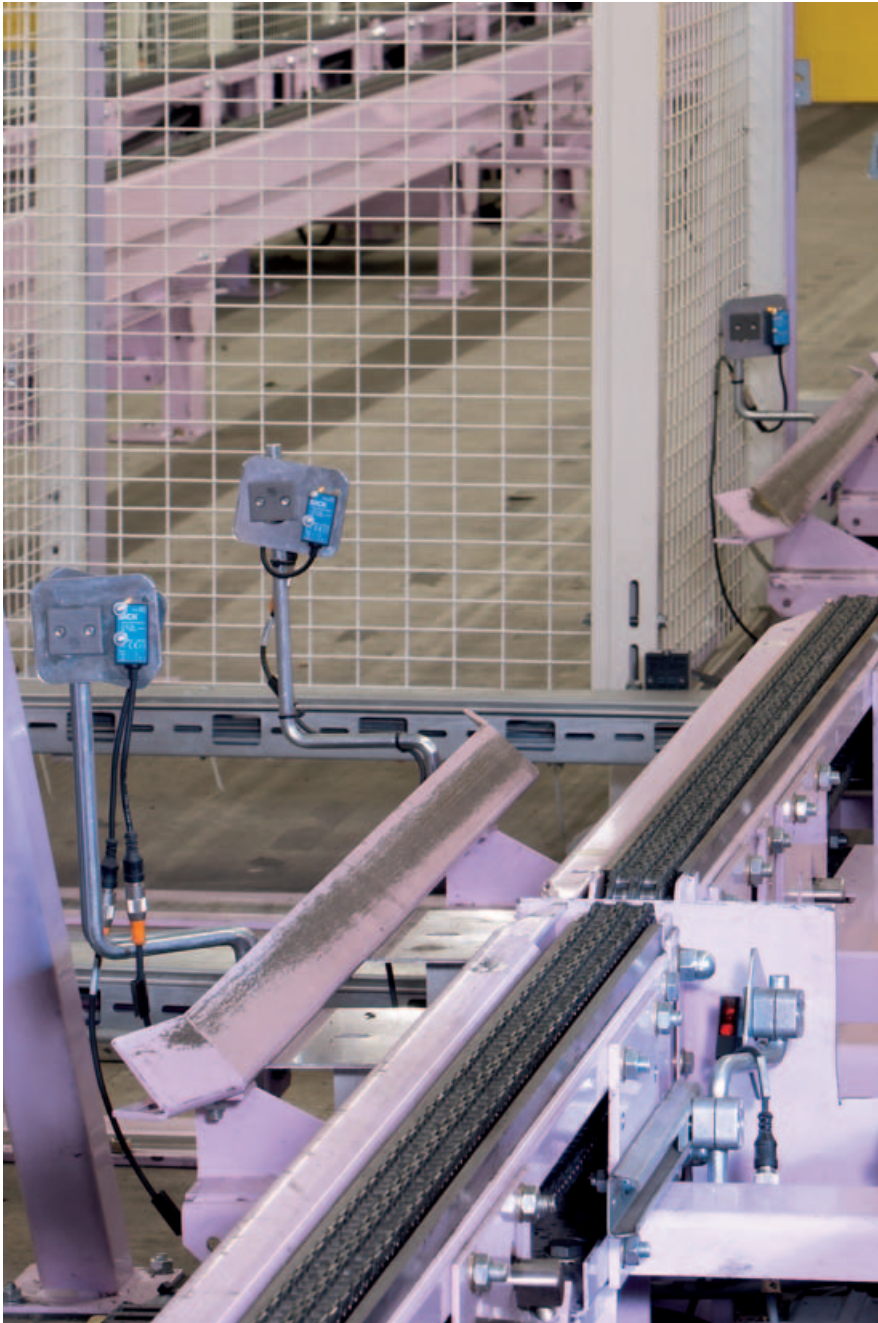

▲ W 9-2 in warehousing and conveying technology; universally installed, secure, compact.

◀ W 9-2 highest variety of products referring to operating principle, features and connectors in one housing.



► W 9-2 in the packaging industry; high availability, easy to operate.

**Scanning distance**  
30 ... 250 mm

Photoelectric proximity switches

- Precise, easily adjustable background suppression
- Insensitive to ambient light sources
- Security against interference from other sensors installed adjacently
- Permissible ambient operating temperature -40 °C ... +60 °C
- Fast response times, enabling fast processes

**Dimensional drawing**

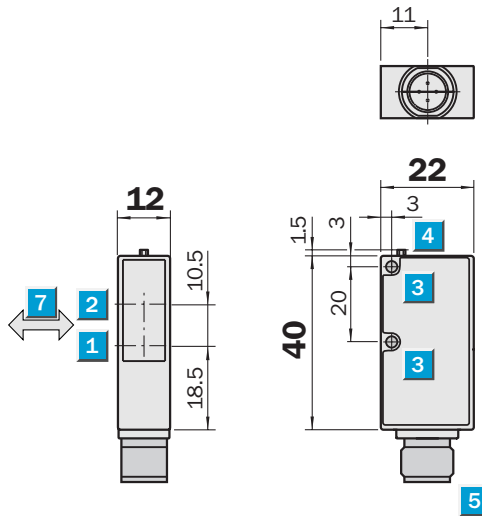

**Adjustments possible**

WT 9-2P 130	WT 9-2P 330
WT 9-2P 430	WT 9-2P 630
WT 9-2N 130	
WT 9-2N 430	

- 1 Axis of the sender optics
- 2 Axis of the receiver optics
- 3 Mounting hole Ø 3.2 mm
- 4 LED signal strength indicator
- 5 Plug M12 or M8, 4-pin, 2 m connection cable or 120 mm cable with plug M12, 4-pin
- 6 Scanning distance adjuster
- 7 Standard direction of the material to be scanned

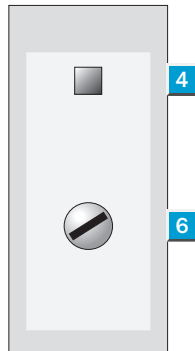

**Connection types**

WT 9-2P 130	WT 9-2P 330	WT 9-2P 430	WT 9-2P 630
WT 9-2N 130		WT 9-2N 430	

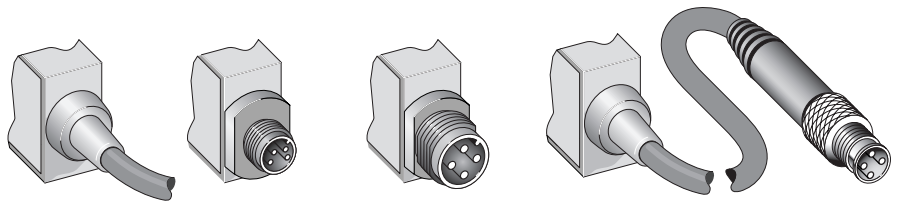

4 x 0.14 mm <sup>2</sup>	4-pin, M8	4-pin, M12	4-pin, M12 with 120 mm cable
--------------------------	-----------	------------	------------------------------

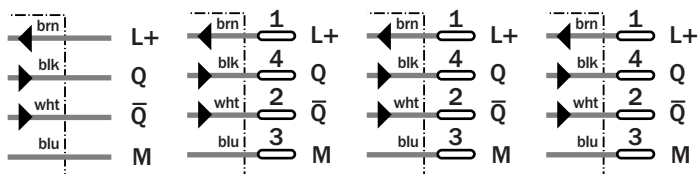

**See chapter Accessories**

Cables and connectors
Mounting systems

Technical data		WT 9-2	P 130	P 430	N 130	N 430	P 330	P 630				
<b>Scanning distance adjustable <sup>1)</sup></b>	30 ... 250 mm											
Scanning range	5 ... 250 mm											
<b>Supply voltage <math>V_S</math><sup>2)</sup></b>	10 ... 30 VDC											
Ripple <sup>3)</sup>	$\leq 5 V_{pp}$											
Current consumption <sup>4)</sup>	$\leq 40 \text{ mA}$											
<b>Light source</b>	LED, visible red light <sup>5)</sup>											
Light spot diameter	15 x 15 mm at 200 mm											
<b>Switching outputs Q and <math>\bar{Q}</math></b>	PNP											
	NPN											
Signal voltage HIGH	$V_S - 2.9 \text{ V}$											
	$V_S$											
Signal voltage LOW <sup>6)</sup>	Approx. 0 V											
	$\leq 1.5 \text{ V}$											
<b>Output current <math>I_A</math> max.</b>	$\leq 100 \text{ mA}$											
<b>Response time <sup>7)</sup></b>	$\leq 333 \mu\text{s}$											
<b>Switching frequency max. <sup>8)</sup></b>	1500/s											
<b>Connection types</b>	Connection cable, 2 m											
	Cable, 120 mm, with plug M12, 4-pin											
	Plug M12, 4-pin											
	Plug M8, 4-pin											
<b>VDE protection class M12<sup>9)</sup></b>	<input type="checkbox"/>											
<b>VDE protection class M8</b>	III											
<b>Enclosure rating</b>	IP 67, IP 69K											
<b>Circuit protection <sup>10)</sup></b>	A, B, C											
<b>Ambient temperature <math>T_A</math> <sup>11)</sup></b>	Operation - 40 ... + 60 °C											
	Storage - 40 ... + 75 °C											
<b>Weight</b>												
with connection cable 2 m/120 mm	Approx. 80 g											
with equipment plug M12/M8, 4-pin	Approx. 20 g											

1) Object with 90% remission (referred to standard white DIN 5033)  
 2) Limit values  
 3) Must be within  $V_S$  tolerances  
 4) Without load

5) Average service life at room temperature 100,000 h at  $T_A = + 25 \text{ °C}$   
 6) At  $T_A = + 25 \text{ °C}$  and 100 mA output current

7) With resistive load  
 8) With light/dark ratio 1:1  
 9) Reference voltage 50 V

10) A = supply connections reverse polarity protected  
 B = outputs short-circuit protected  
 C = interference suppression  
 11) Do not bend below 0 °C

**Scanning distance**

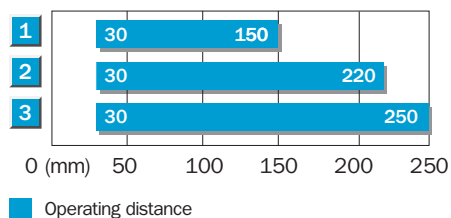

- 1 Scanning distance on black, 6% remission
- 2 Scanning distance on gray, 18% remission
- 3 Scanning distance on white, 90% remission

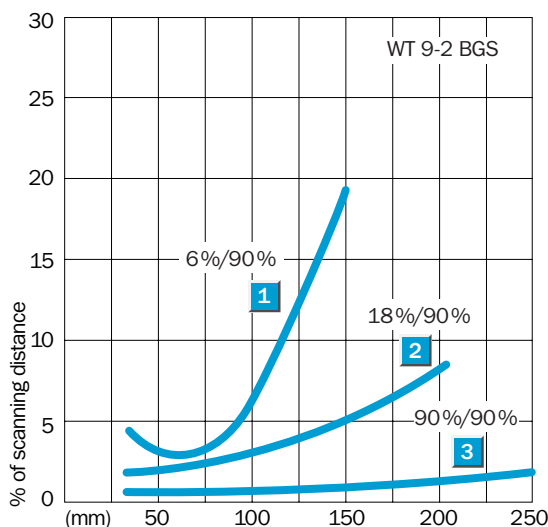

**Order information**

Type	Order no.
WT 9-2P 130	1 018 293
WT 9-2P 430	1 018 295
WT 9-2N 130	1 018 294
WT 9-2N 430	1 018 296
WT 9-2P 330	1 019 026
WT 9-2P 630	1 019 272

**Scanning distance**  
 30 ... 250 mm

Photoelectric proximity switches

- Precise, easily adjustable background suppression
- Insensitive to ambient light sources
- Security against interference from other sensors installed adjacently
- Permissible ambient operating temperature -40 °C ... +60 °C
- Fast response times, enabling fast processes

Dimensional drawing

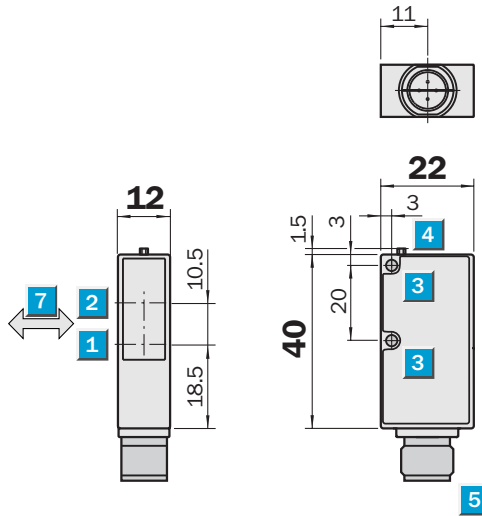

Adjustments possible

- WT 9-2P110
- WT 9-2P310
- WT 9-2P410

- 1 Axis of the sender optics
- 2 Axis of the receiver optics
- 3 Mounting hole  $\varnothing$  3.2 mm
- 4 LED signal strength indicator
- 5 2 m connection cable or plug M12, 4-pin
- 6 Scanning distance adjuster
- 7 Standard direction of the material to be scanned

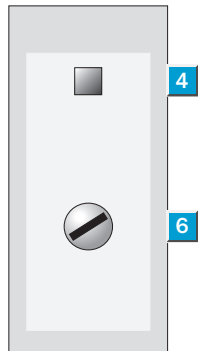

Connection types

WT 9-2P110

WT 9-2P310

WT 9-2P410

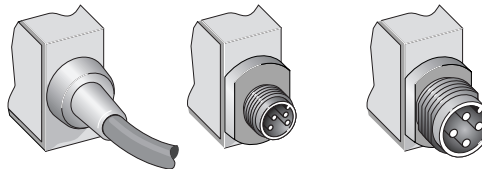

4 x 0.14 mm<sup>2</sup>

4-pin, M8

4-pin, M12

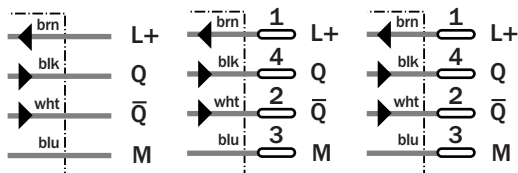

See chapter Accessories

- Cables and connectors
- Mounting systems



Technical data		WT 9-2	P110	P310	P410						
<b>Scanning distance, adjustable <sup>1)</sup></b>	30 ... 250 mm										
Scanning range	5 ... 30 mm und 10 ... 250 mm										
<b>Supply voltage <math>V_S</math><sup>2)</sup></b>	10 ... 30 VDC										
Ripple <sup>3)</sup>	$\leq 5 V_{PP}$										
Current consumption <sup>4)</sup>	$\leq 30$ mA										
<b>Light source <sup>5)</sup></b>	LED, infrared										
Light spot diameter	15 x 15 mm at a distance of 200 mm										
<b>Switching outputs</b>	PNP, Q und $\bar{Q}$										
Signal voltage HIGH	$V_S - 2.9$ V										
Signal voltage LOW <sup>6)</sup>	Approx. 0 V										
<b>Output current <math>I_A</math> max.</b>	$\leq 100$ mA										
<b>Response time <sup>7)</sup></b>	$\leq 500$ $\mu$ s										
<b>Switching frequency max. <sup>8)</sup></b>	1000/s										
<b>Connection technology</b>	Connection cable, 2 m										
	Plug M 8, 4-pin										
	Plug M12, 4-pin										
<b>VDE protection class <sup>9)</sup></b>	<input type="checkbox"/>										
<b>Protection type</b>	IP 67, IP 69K										
<b>Protection circuits <sup>10)</sup></b>	A, B, C										
<b>Ambient temperature <sup>11)</sup></b>	Operation $-40 \dots +60$ °C										
	Storage $-40 \dots +75$ °C										
<b>Weight</b>	with cable 2 m	Approx. 80 g									
	with M12 plug	Approx. 20 g									

1) Object with 90% reflectance (referred to standard white DIN 5033)  
 2) Limit values  
 3) Must be within  $V_S$  tolerances  
 4) Without load

5) Average service life at room temperature 100,000 h at  $T_U = +25$  °C  
 6) At  $T_U = +25$  °C and 100 mA output current

7) With resistive load  
 8) With light/dark ratio 1:1  
 9) Withstand voltage 50 V DC

10) A = supply connections reverse polarity protected  
 B = outputs short-circuit protected  
 C = interference suppression  
 11) Do not distort cable below 0 °C

**Scanning distance**

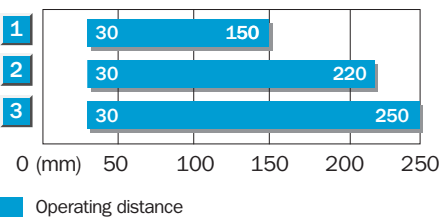

- 1 Scanning distance on black, 6% remission
- 2 Scanning distance on gray, 18% remission
- 3 Scanning distance on white, 90% remission

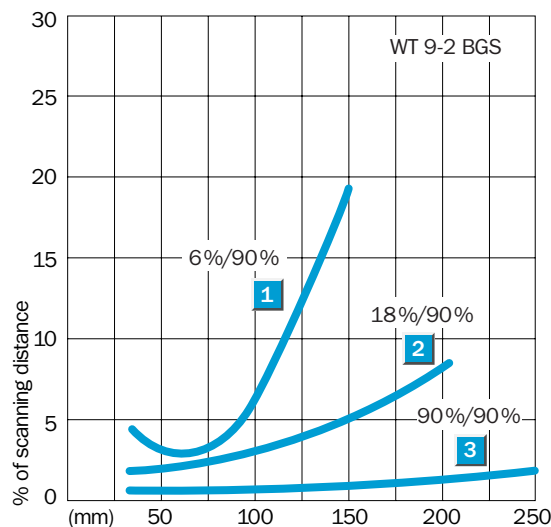

**Order information**

Type	Order no.
WT 9-2P110	1 018 577
WT 9-2P310	1 028 279
WT 9-2P410	1 019 668

**Scanning distance**  
**30 ... 500 mm**

Photoelectric proximity switches

- Easily adjustable background blanking
- Insensitive to ambient light sources
- Security against interference from other sensors installed adjacently
- Permissible ambient operating temperature -40 °C ... +60 °C
- Fast response times, enabling fast processes

**Dimensional drawing**

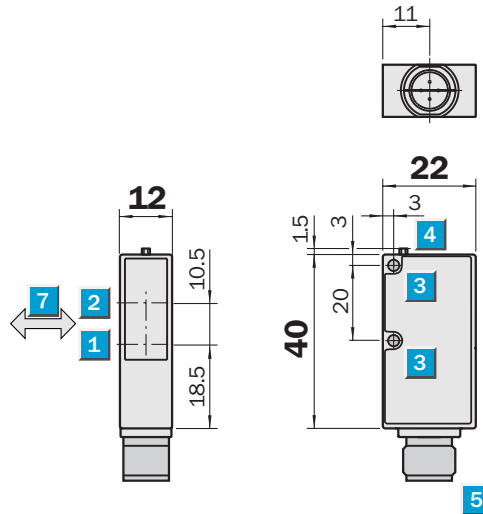

**Adjustments possible**

WT 9-2P620

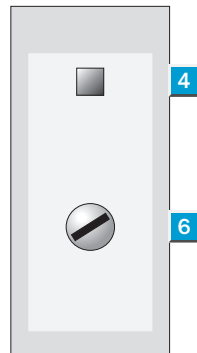

- 1** Axis of the receiver optics
- 2** Axis of the sender optics
- 3** Mounting hole  $\varnothing$  3.2 mm
- 4** LED signal strength indicator
- 5** 120 mm cable with plug M12, 4-pin
- 6** Scanning distance adjuster
- 7** Standard direction of the material to be scanned

**Connection types**

WT 9-2P620

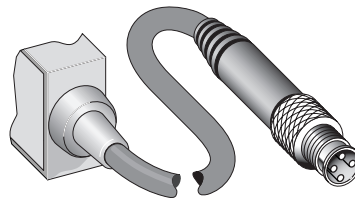

4-pin, M12 with 120 mm cable

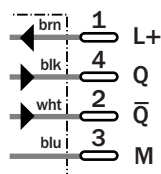

See chapter Accessories

Cables and connectors

Mounting systems

**Technical data** WT 9-2 P620

<b>Scanning distance, adjustable <sup>1)</sup></b>	30 ... 500 mm
<b>Supply voltage <math>V_S</math><sup>2)</sup></b>	10 ... 30 V DC
Ripple <sup>3)</sup>	$\leq 5 V_{PP}$
Current consumption <sup>4)</sup>	$\leq 30$ mA
<b>Light source <sup>5)</sup></b>	LED, infrared
Light spot diameter	15 x 15 mm at a distance of 200 mm
<b>Switching outputs</b>	PNP, Q und $\bar{Q}$
Signal voltage HIGH	$V_S - 2.9$ V
Signal voltage LOW <sup>6)</sup>	Approx. 0 V
<b>Output current <math>I_A</math> max.</b>	$\leq 100$ mA
<b>Response time <sup>7)</sup></b>	$\leq 333 \mu s$
<b>Switching frequency max. <sup>8)</sup></b>	1500/s
<b>Connection technology</b>	Cable, 120 mm, with plug M12, 4-pin
<b>VDE protection class <sup>9)</sup></b>	<input type="checkbox"/>
<b>Protection type</b>	IP 67, IP 69K
<b>Protection circuits <sup>10)</sup></b>	A, B, C
<b>Ambient temperature <sup>11)</sup></b>	Operation $-40 \dots +60$ °C Storage $-40 \dots +75$ °C
<b>Weight with cable 120 mm</b>	Approx. 80 g
<b>Housing material</b>	ABS

1) Object with 18% reflectance (referred to standard white DIN 5033)  
 2) Limit values  
 3) Must be within  $V_S$  tolerances  
 4) Without load  
 5) Average service life temperature 100,000 h at  $T_U = +25$  °C  
 6) At  $T_U = +25$  °C and 100 mA output current  
 7) With resistive load  
 8) With light/dark ratio 1:1  
 9) Withstand voltage 50 V  
 10) A = Supply connections reverse polarity protected  
 B = Outputs short-circuit protected  
 C = Interference suppression  
 11) Do not distort cable below 0 °C

**Scanning distance**

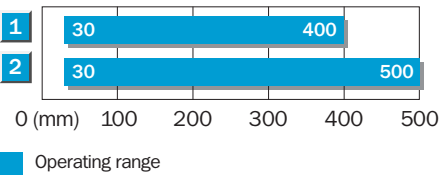

- 1 Scanning range on black, 6% remission
- 2 Scanning range on gray, 18% remission

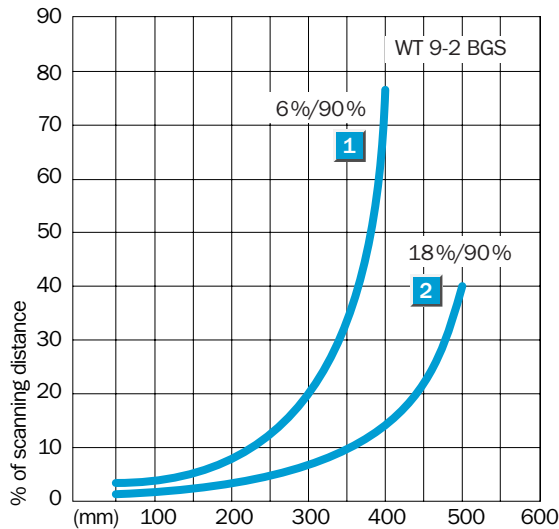

**Order information**

<b>Type</b>	<b>Order no.</b>
WT 9-2P620	1 019 711





**Scanning distance**  
**50 ... 1500 mm**

Photoelectric proximity switches

- Emitter LED IR
- Scanning distance adjustable
- Switching frequency 500/s
- 2 m connection cable or plug M12, 4-pin
- Outputs short-circuit protected
- Permissible ambient operating temperature  $-40\text{ °C} \dots +60\text{ °C}$

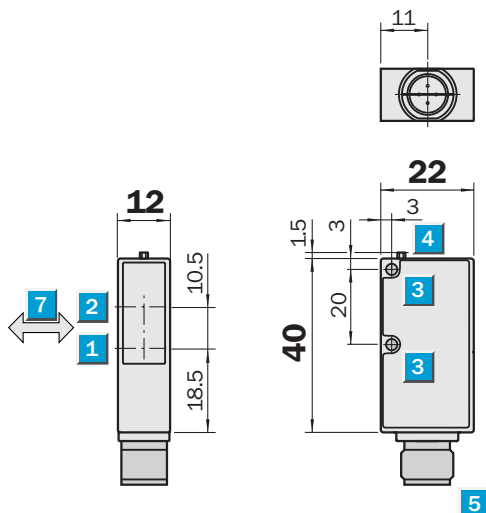
## Dimensional drawing



## Adjustments possible

WT 9-2P460
WT 9-2P160
WT 9-2N160

- 1** Axis of the receiver optics
- 2** Axis of the sender optics
- 3** Mounting hole  $\varnothing 3.2\text{ mm}$
- 4** LED signal strength indicator
- 5** 2 m connection cable or plug M12, 4-pin
- 6** Scanning distance adjuster
- 7** Standard direction of the material to be scanned

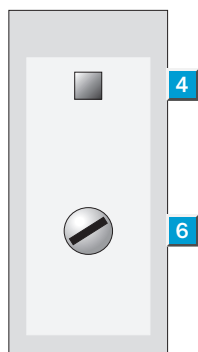

## Connection types

WT 9-2P160	WT 9-2P460
WT 9-2N160	

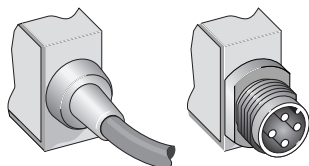

### 4 x 0.14 mm<sup>2</sup>

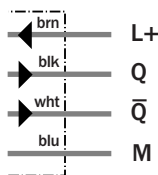

### 4-pin, M12

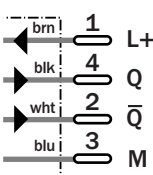

## See chapter Accessories

- Cables and connectors
- Mounting systems

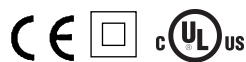

Technical data		WT 9-2	P160	P460	N160						
<b>Scanning distance, adjustable <sup>1)</sup></b>	50 ... 1500 mm										
<b>Supply voltage <math>V_S</math><sup>2)</sup></b>	10 ... 30 V DC										
Ripple <sup>3)</sup>	$\leq 5 V_{pp}$										
Current consumption <sup>4)</sup>	$\leq 30 \text{ mA}$										
<b>Light source <sup>5)</sup></b>	LED, infrared										
Light spot diameter	600 mm at a distance of 1500 mm										
<b>Switching outputs</b>	PNP, Q und $\bar{Q}$										
	NPN, Q und $\bar{Q}$										
Signal voltage HIGH	$V_S - 2.9 \text{ V}$										
	$V_S$										
Signal voltage LOW <sup>6)</sup>	Approx. 0 V										
	$< 2.9 \text{ V}$										
<b>Output current <math>I_A \text{ max.}</math></b>	$\leq 100 \text{ mA}$										
<b>Response time <sup>7)</sup></b>	$\leq 1000 \mu\text{s}$										
<b>Switching frequency max. <sup>8)</sup></b>	500/s										
<b>Connection technology</b>	Connection cable, 2 m										
	Plug M12, 4-pin										
<b>VDE protection class <sup>9)</sup></b>	$\square$										
<b>Protection type</b>	IP 67, IP 69K										
<b>Protection circuits <sup>10)</sup></b>	A, B, C										
<b>Ambient temperature <sup>11)</sup></b>	Operation $-40 \dots +60 \text{ }^\circ\text{C}$										
	Storage $-40 \dots +75 \text{ }^\circ\text{C}$										
<b>Weight</b> with cable 2 m	Approx. 80 g										
with plug	Approx. 20 g										

1) Object with 90% reflectance (referred to standard white DIN 5033)  
 2) Limit values  
 3) Must be within  $V_S$  tolerances  
 4) Without load

5) Average service life at room temperature 100,000 h at  $T_U = +25 \text{ }^\circ\text{C}$   
 6) At  $T_U = +25 \text{ }^\circ\text{C}$  and 100 mA output current

7) With resistive load  
 8) With light/dark ratio 1:1  
 9) Withstand voltage 50 V DC

10) A = supply connections reverse polarity protected  
 B = outputs short-circuit protected  
 C = interference suppression  
 11) Do not distort cable below 0 °C

**Scanning distance**

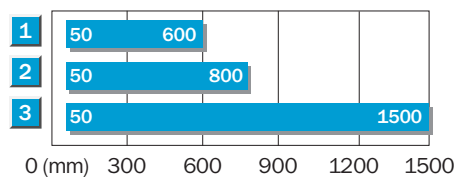

Operating distance

- 1 Scanning range on black, 6% remission
- 2 Scanning range on gray, 18% remission
- 3 Scanning range on white, 90% remission

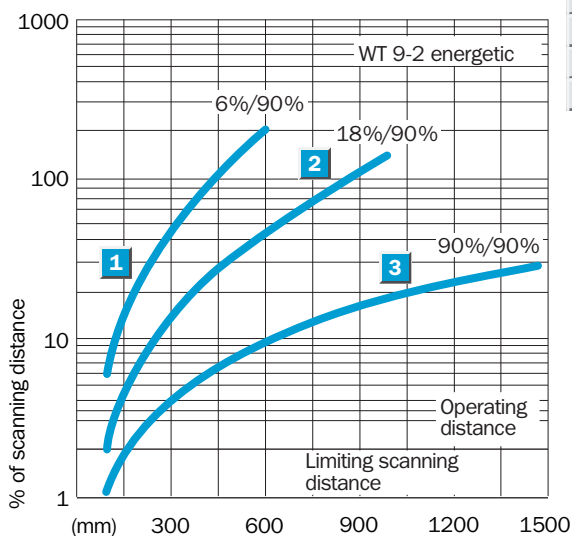

**Order information**

Type	Order no.
WT 9-2P160	1 019 097
WT 9-2P460	1 019 098
WT 9-2 N160	1 019 342

 **Scanning distance**  
10 ... 450 mm

Photoelectric proximity switches

- Red-light emitter LED as alignment aid
- Adjustable scanning distance
- Switching frequency 800/s
- Outputs short-circuit protected
- Sensitivity adjustment using the Teach-in procedure
- Permissible ambient operating temperature -40 °C ... +60 °C

**Dimensional drawing**

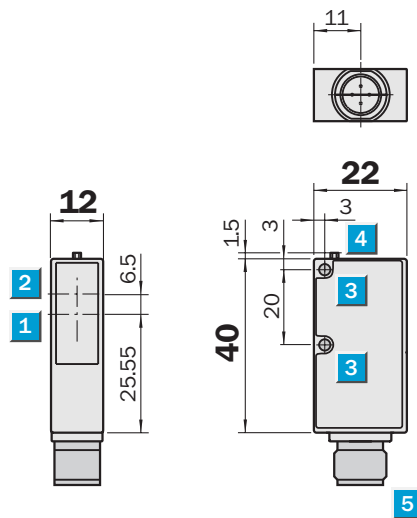

**Adjustments possible**

WT 9-2P 151	WT 9-2P 351
WT 9-2P 451	WT 9-2P 651
WT 9-2N 151	
WT 9-2N 451	

- 1 Axis of the receiver optics
- 2 Axis of the sender optics
- 3 Mounting hole Ø 3.2 mm
- 4 LED signal strength indicator
- 5 Plug M12 or M8, 4-pin, 2 m connection cable or 120 mm cable with plug M12, 4-pin
- 6 Teach-in button

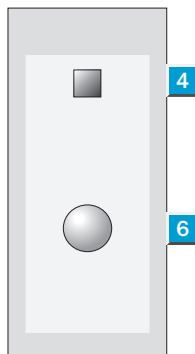

**Connection types**

WT 9-2P 151	WT 9-2P 351	WT 9-2P 451	WT 9-2P 651
WT 9-2N 151		WT 9-2N 451	

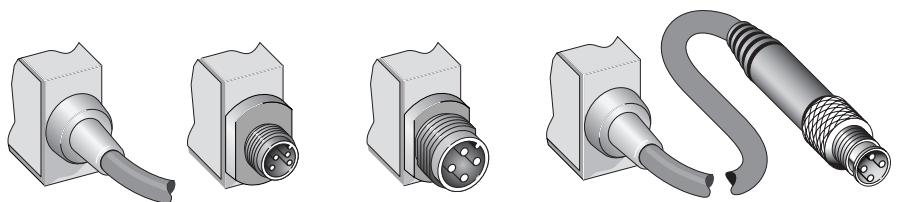

4 x 0.14 mm <sup>2</sup>	4-pin, M8	4-pin, M12	4-pin, M12 with 120 mm cable
--------------------------	-----------	------------	------------------------------

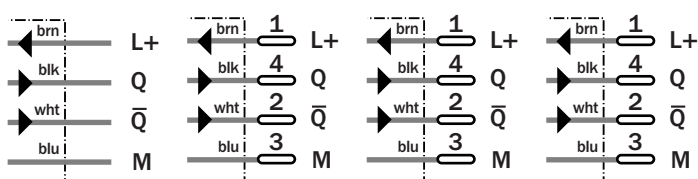

**See chapter Accessories**

Cables and connectors
Mounting systems

Technical data		WT 9-2	P 151	P 451	N 151	N 451	P 351	P 651				
<b>Scanning distance adjustable <sup>1)</sup></b>	10 ... 450 mm											
<b>Supply voltage <math>V_S</math><sup>2)</sup></b>	10 ... 30 V DC											
Ripple <sup>3)</sup>	$\leq 5 V_{pp}$											
Current consumption <sup>4)</sup>	$\leq 30$ mA											
<b>Light source</b>	LED, visible red light <sup>5)</sup>											
Light spot diameter	80 x 80 mm at 500 mm											
<b>Switching outputs Q and <math>\bar{Q}</math></b>	PNP											
	NPN											
Signal voltage HIGH	$V_S - 2.9$ V											
	$V_S$											
Signal voltage LOW <sup>6)</sup>	Approx. 0 V											
	$\leq 2.9$ V											
<b>Output current <math>I_A</math> max.</b>	$\leq 100$ mA											
<b>Response time <sup>7)</sup></b>	$\leq 625$ $\mu$ s											
<b>Switching frequency max. <sup>8)</sup></b>	800/s											
<b>Connection types</b>	Connection cable, 2 m											
	Cable, 120 mm, with plug M12, 4-pin											
	Plug M12, 4-pin											
	Plug M8, 4-pin											
<b>VDE protection class M12<sup>9)</sup></b>	<input type="checkbox"/>											
<b>VDE protection class M8</b>	III											
<b>Enclosure rating</b>	IP 67, IP 69K											
<b>Circuit protection <sup>10)</sup></b>	A, B, C											
<b>Ambient temperature <math>T_A</math> <sup>11)</sup></b>	Operation - 40 ... + 60 °C											
	Storage - 40 ... + 75 °C											
<b>Weight</b>												
with connection cable 2 m/120 mm	Approx. 80 g											
with equipment plug M12/M8, 4-pin	Approx. 20 g											

1) Object with 90% remission (referred to standard white DIN 5033)  
 2) Limit values  
 3) Must be within  $V_S$  tolerances  
 4) Without load

5) Average service life at room temperature 100,000 h at  $T_A = + 25$  °C  
 6) At  $T_A = + 25$  °C and 100 mA output current

7) With resistive load  
 8) With light/dark ratio 1:1  
 9) Reference voltage 50 V

10) A = supply connections reverse polarity protected  
 B = outputs short-circuit protected  
 C = interference suppression  
 11) Do not bend below 0 °C

**Teach-in function**

- **Programming via Teach-in button.**
- **Simple programming:**  
Position object in the beam and push the button: finished;  
LED confirms the Teach-in procedure.
- **Teach-in values can be stored.**

- **Two operating modes:**  
**Default setting:** short Teach-in time (< 8 s); for standard applications; approx. double reserve via switching threshold; LED lights continuously.  
**Precise setting:** long Teach-in time (> 8 s); for precise applications; small switching hysteresis; LED blinks.

**Scanning distance**

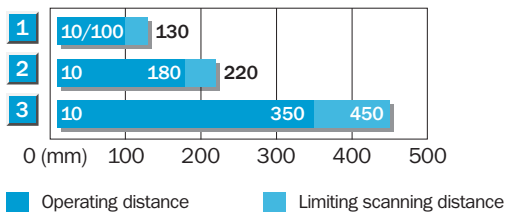

- 1 Scanning range on black, 6% remission
- 2 Scanning range on gray, 18% remission
- 3 Scanning range on white, 90% remission

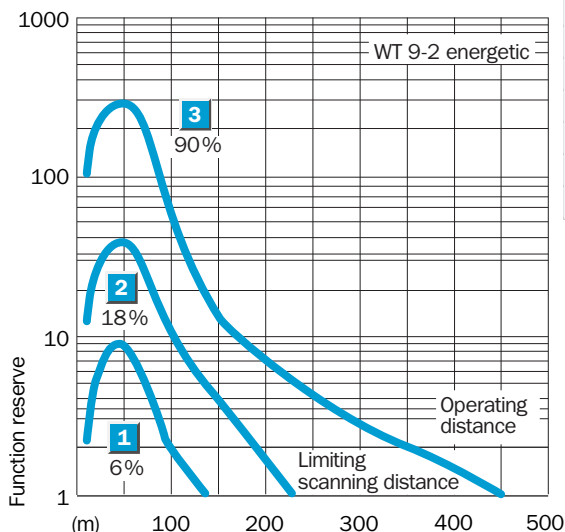

**Order information**

Type	Order no.
WT 9-2P 151	1 018 297
WT 9-2P 451	1 018 299
WT 9-2N 151	1 018 298
WT 9-2N 451	1 018 300
WT 9-2P 351	1 019 027
WT 9-2P 651	1 019 273

**Scanning distance**  
10 ... 20 mm

Photoelectric proximity switches

- Red-light emitter LED as alignment aid
- Adjustable scanning distance
- Switching frequency 800/s
- Outputs short-circuit protected
- Sensitivity adjustment using the Teach-in procedure
- Permissible ambient operating temperature -40 °C ... +60 °C

**Dimensional drawing**

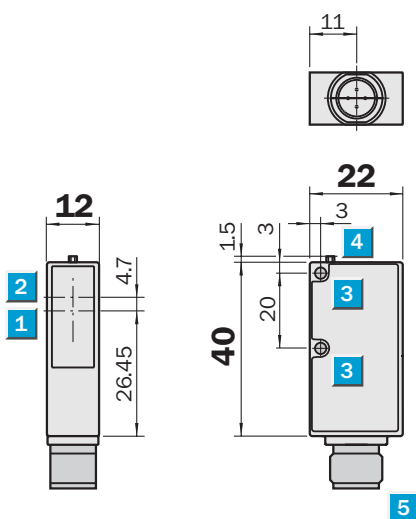

**Adjustments possible**

WT 9-2P 141	WT 9-2P 341
WT 9-2P 441	WT 9-2P 641
WT 9-2N 141	
WT 9-2N 441	

- 1 Axis of the receiver optics
- 2 Axis of the emitter optics
- 3 Mounting hole Ø 3.2 mm
- 4 LED signal strength indicator
- 5 Plug M12 or M8, 4-pin, 2 m connection cable or 120 mm cable with plug M12, 4-pin
- 6 Teach-in button

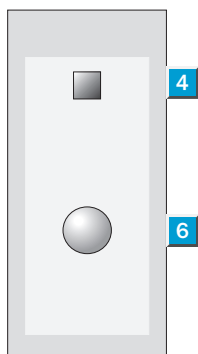

**Connection types**

WT 9-2P 141	WT 9-2P 341	WT 9-2P 441	WT 9-2P 641
WT 9-2N 141		WT 9-2N 441	

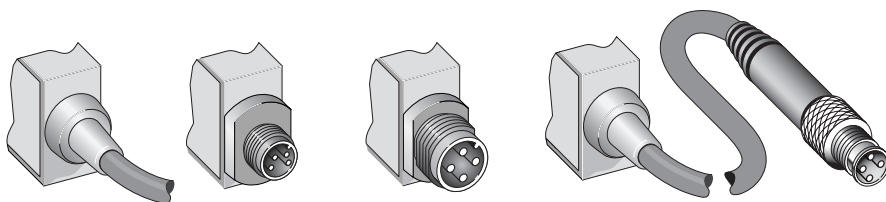

**See chapter Accessories**

Cables and connectors
Mounting systems

4 x 0.14 mm <sup>2</sup>	4-pin, M8	4-pin, M12	4-pin, M12 with 120 mm cable																																
<table border="0"> <tr><td>← brn  </td><td>L+</td></tr> <tr><td>→ blk  </td><td>Q</td></tr> <tr><td>→ wht  </td><td>Q̄</td></tr> <tr><td>← blu  </td><td>M</td></tr> </table>	← brn	L+	→ blk	Q	→ wht	Q̄	← blu	M	<table border="0"> <tr><td>← brn   1</td><td>L+</td></tr> <tr><td>→ blk   4</td><td>Q</td></tr> <tr><td>→ wht   2</td><td>Q̄</td></tr> <tr><td>← blu   3</td><td>M</td></tr> </table>	← brn   1	L+	→ blk   4	Q	→ wht   2	Q̄	← blu   3	M	<table border="0"> <tr><td>← brn   1</td><td>L+</td></tr> <tr><td>→ blk   4</td><td>Q</td></tr> <tr><td>→ wht   2</td><td>Q̄</td></tr> <tr><td>← blu   3</td><td>M</td></tr> </table>	← brn   1	L+	→ blk   4	Q	→ wht   2	Q̄	← blu   3	M	<table border="0"> <tr><td>← brn   1</td><td>L+</td></tr> <tr><td>→ blk   4</td><td>Q</td></tr> <tr><td>→ wht   2</td><td>Q̄</td></tr> <tr><td>← blu   3</td><td>M</td></tr> </table>	← brn   1	L+	→ blk   4	Q	→ wht   2	Q̄	← blu   3	M
← brn	L+																																		
→ blk	Q																																		
→ wht	Q̄																																		
← blu	M																																		
← brn   1	L+																																		
→ blk   4	Q																																		
→ wht   2	Q̄																																		
← blu   3	M																																		
← brn   1	L+																																		
→ blk   4	Q																																		
→ wht   2	Q̄																																		
← blu   3	M																																		
← brn   1	L+																																		
→ blk   4	Q																																		
→ wht   2	Q̄																																		
← blu   3	M																																		

Technical data		WT 9-2	P 141	P 441	N 141	N 441	P 341	P 641				
<b>Scanning distance adjustable <sup>1)</sup></b>	10 ... 20 mm											
<b>Supply voltage <math>V_S</math> <sup>2)</sup></b>	10 ... 30 VDC											
Ripple <sup>3)</sup>	$\leq 5 V_{pp}$											
Current consumption <sup>4)</sup>	$\leq 30 \text{ mA}$											
<b>Light source</b>	LED, visible red light <sup>5)</sup>											
Light spot diameter	3 mm at 20 mm											
<b>Switching outputs Q and <math>\bar{Q}</math></b>	PNP											
	NPN											
Signal voltage HIGH	$V_S - 2.9 \text{ V}$											
	$V_S$											
Signal voltage LOW <sup>6)</sup>	Approx. 0 V											
	$\leq 2.9 \text{ V}$											
<b>Output current <math>I_A</math> max.</b>	$\leq 100 \text{ mA}$											
<b>Response time <sup>7)</sup></b>	$\leq 625 \mu\text{s}$											
<b>Switching frequency max. <sup>8)</sup></b>	800/s											
<b>Connection types</b>	Connection cable, 2 m											
	Cable, 120 mm, with plug M12, 4-pin											
	Plug M12, 4-pin											
	Plug M8, 4-pin											
<b>VDE protection class M12 <sup>9)</sup></b>	<input type="checkbox"/>											
<b>VDE protection class M8</b>	III											
<b>Enclosure rating</b>	IP 67, IP 69K											
<b>Circuit protection <sup>10)</sup></b>	A, B, C											
<b>Ambient temperature <math>T_A</math> <sup>11)</sup></b>	Operation $-40 \dots +60 \text{ }^\circ\text{C}$											
	Storage $-40 \dots +75 \text{ }^\circ\text{C}$											
<b>Weight</b>												
with connection cable 2 m/120 mm	Approx. 80 g											
with equipment plug M12/M8, 4-pin	Approx. 20 g											

1) Object with 90% remission (referred to standard white DIN 5033)  
 2) Limit values  
 3) Must be within  $V_S$  tolerances  
 4) Without load

5) Average service life at room temperature 100,000 h at  $T_A = +25 \text{ }^\circ\text{C}$   
 6) At  $T_A = +25 \text{ }^\circ\text{C}$  and 100 mA output current

7) With resistive load  
 8) With light/dark ratio 1:1  
 9) Reference voltage 50 V

10) A = supply connections reverse polarity protected  
 B = outputs short-circuit protected  
 C = interference suppression  
 11) Do not bend below 0 °C

**Teach-in function**

- **Programming via Teach-in button.**
- **Simple programming:**  
Position object in the beam and push the button: finished;  
LED confirms the Teach-in procedure.
- **Teach-in values can be stored.**

- **Two operating modes:**  
**Default setting:** short Teach-in time (< 8 s);  
for standard applications;  
approx. double reserve via switching threshold;  
LED lights continuously.  
**Precise setting:** long Teach-in time (> 8 s);  
for precise applications;  
small switching hysteresis;  
LED blinks.

**Scanning distance**

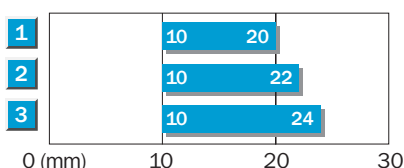

Operating distance

- 1 Scanning range on black, 6% remission
- 2 Scanning range on gray, 18% remission
- 3 Scanning range on white, 90% remission

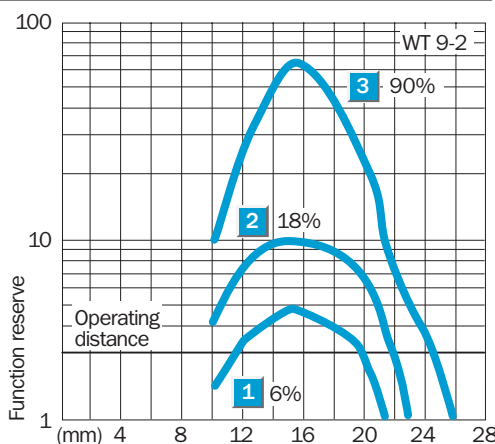

**Order information**

Type	Order no.
WT 9-2P 141	1 018 301
WT 9-2P 441	1 018 303
WT 9-2N 141	1 018 302
WT 9-2N 441	1 018 304
WT 9-2P 341	1 019 274
WT 9-2P 641	1 019 275

**Scanning distance**  
**10 ... 20 mm**

Photoelectric proximity switches

- Emitter LED IR
- Switching frequency 800/s
- Outputs short-circuit protected
- 120 mm cable with plug M12, 4-pin
- Scanning distance adjustment via Teach-in button
- Permissible ambient operating temperature -40 °C ... +60 °C

**Dimensional drawing**

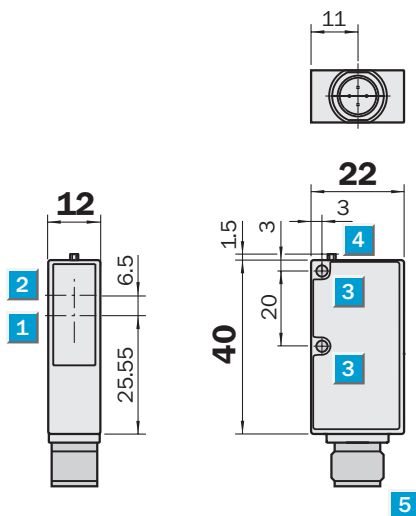

**Adjustments possible**

WT 9-2P671

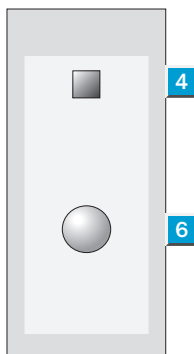

- 1** Axis of the receiver optics
- 2** Axis of the sender optics
- 3** Mounting hole  $\varnothing$  3.2 mm
- 4** LED signal strength indicator
- 5** 120 mm cable with plug M12, 4-pin
- 6** Teach-in button

**Connection types**

WT 9-2P671

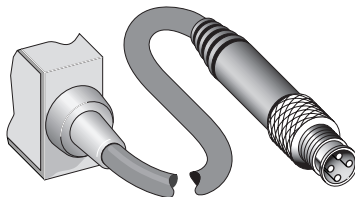

4-pin, M12 with 120 mm cable

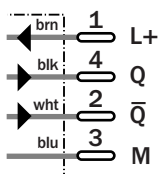

<b>See chapter Accessories</b>
Cables and connectors
Mounting systems

Technical data WT 9-2 P671

<b>Scanning distance, teachable <sup>1)</sup></b>	10 ... 20 mm
<b>Supply voltage <math>V_S</math><sup>2)</sup></b>	10 ... 30 V DC
Ripple <sup>3)</sup>	$\leq 5 V_{PP}$
Current consumption <sup>4)</sup>	$\leq 30$ mA
<b>Light source <sup>5)</sup></b>	LED, infrared
Light spot diameter	3 mm at a distance of 20 mm
<b>Switching outputs</b>	PNP, Q und $\bar{Q}$
Signal voltage HIGH	$V_S - 2.9$ V
Signal voltage LOW <sup>6)</sup>	Approx. 0 V
<b>Output current <math>I_A</math> max.</b>	$\leq 100$ mA
<b>Response time <sup>7)</sup></b>	$\leq 625$ $\mu$ s
<b>Switching frequency max. <sup>8)</sup></b>	800/s
<b>Connection technology</b>	Cable, 120 mm, with plug M12, 4-pin
<b>VDE protection class <sup>9)</sup></b>	<input type="checkbox"/>
<b>Protection type</b>	IP 67, IP 69K
<b>Protection circuits <sup>10)</sup></b>	A, B, C
<b>Ambient temperature <sup>11)</sup></b>	Operation $-40 \dots +60$ °C Storage $-40 \dots +75$ °C
<b>Weight with cable 120 mm</b>	Approx. 80 g
<b>Housing material</b>	ABS

- <sup>1)</sup> Object with 90% reflectance (referred to standard white DIN 5033)
- <sup>2)</sup> Limit values
- <sup>3)</sup> Must be within  $V_S$  tolerances
- <sup>4)</sup> Without load
- <sup>5)</sup> Average service life at room temperature 100,000 h at  $T_U = +25$  °C
- <sup>6)</sup> At  $T_U = +25$  °C and 100 mA output current
- <sup>7)</sup> With resistive load
- <sup>8)</sup> With light/dark ratio 1:1
- <sup>9)</sup> Withstand voltage 50 V DC
- <sup>10)</sup> A = supply connections reverse polarity protected  
B = outputs short-circuit protected  
C = interference suppression
- <sup>11)</sup> Do not distort cable below 0 °C

Teach-in function

- **Programming via teach-in button.**
- **Simple programming:**  
Position object in the beam and push the button: finished;  
LED confirms the teach-in procedure.
- **Teach-in values can be stored.**
- **Two operating modes:**  
**Default setting:** short teach-in time (< 8 s);  
for standard applications;  
approx. double reserve via switching threshold;  
LED lights continuously.  
**Precise setting:** long teach-in time (> 8 s);  
for precise applications;  
small switching hysteresis;  
LED blinks.

Scanning distance

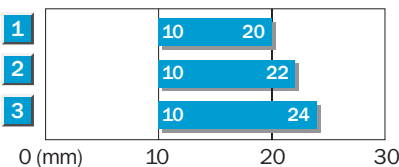

Operating distance

- 1 Scanning range on black, 6% remission
- 2 Scanning range on gray, 18% remission
- 3 Scanning range on white, 90% remission

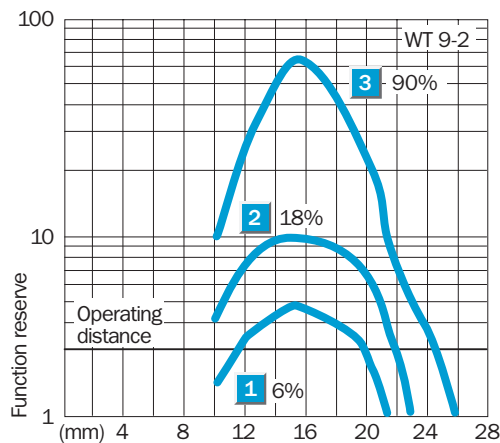

Order information

Type	Order no.
WT 9-2P671	1 019 656



 **Scanning range**  
0 ... 4 m

Photoelectric reflex switches

- Red-light emitter LED as alignment aid
- Switching frequency 800/s
- Outputs short-circuit protected
- Permissible ambient operating temperature -40 °C ... +60 °C

### Dimensional drawing

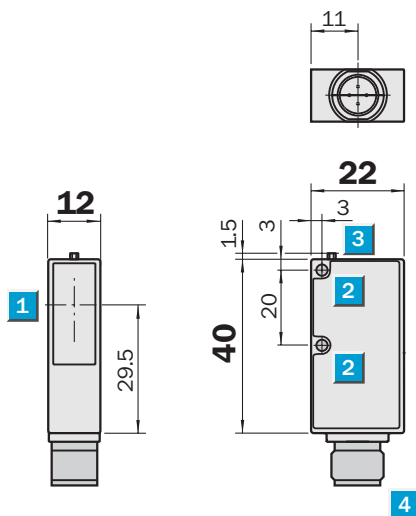

### No setting options

WL 9-2P 130	WL 9-2P 330
WL 9-2P 430	WL 9-2P 630
WL 9-2N 130	WL 9-2N 330
WL 9-2N 430	

- 1 Middle of optic axis
- 2 Mounting hole  $\varnothing$  3.2 mm
- 3 LED signal strength indicator
- 4 Plug M12 or M8, 4-pin, 2 m connection cable or 120 mm cable with plug M12, 4-pin

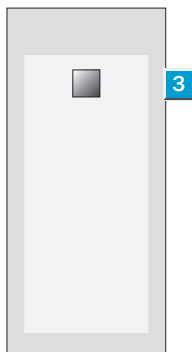

### Connection types

WL 9-2P 130	WL 9-2P 330
WL 9-2N 130	WL 9-2N 330

WL 9-2P 430	WL 9-2P 630
WL 9-2N 430	

WL 9-2P 430	WL 9-2P 630
WL 9-2N 430	

WL 9-2P 430	WL 9-2P 630
WL 9-2N 430	

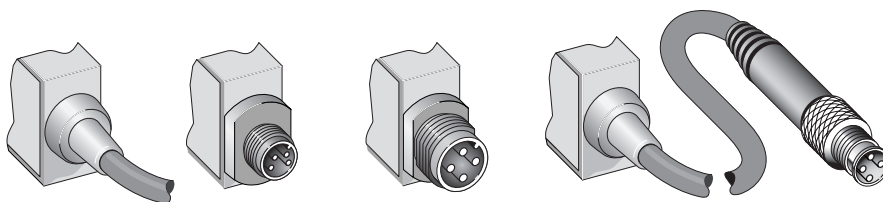

### See chapter Accessories

- Cables and connectors
- Mounting systems
- Reflectors

### 4 x 0.14 mm<sup>2</sup>

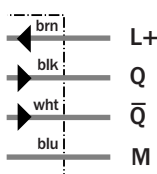

### 4-pin, M8

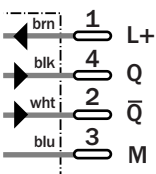

### 4-pin, M12

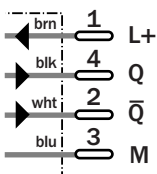

### 4-pin, M12 with 120 mm cable

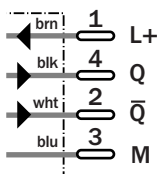

Technical data		WL 9-2	P 130	P 430	N 130	N 430	P 330	P 630	N 330			
<b>Scanning range typ. max./on reflector</b>	4 m/PL 80 A											
<b>Supply voltage <math>V_S</math><sup>1)</sup></b>	10 ... 30 V DC											
Ripple <sup>2)</sup>	$\leq 5 V_{pp}$											
Current consumption <sup>3)</sup>	$\leq 30 \text{ mA}$											
<b>Light source</b>	LED, visible red light <sup>4)</sup>											
Angle of dispersion	2.5°											
Light spot diameter	120 x 120 mm at 3 m											
<b>Switching outputs Q and <math>\bar{Q}</math></b>	PNP											
	NPN											
Signal voltage HIGH	$V_S - 2.9 \text{ V}$											
	$V_S$											
Signal voltage LOW <sup>5)</sup>	Approx. 0 V											
	$\leq 2.9 \text{ V}$											
<b>Output current <math>I_A</math> max.</b>	$\leq 100 \text{ mA}$											
<b>Response time<sup>6)</sup></b>	$\leq 625 \mu\text{s}$											
<b>Max. switching frequency<sup>7)</sup></b>	800/s											
<b>Connection types</b>	Connection cable, 2 m											
	Cable, 120 mm, with plug M12, 4-pin											
	Plug M12, 4-pin											
	Plug M8, 4-pin											
<b>VDE protection class M12<sup>8)</sup></b>	<input type="checkbox"/>											
<b>VDE protection class M8</b>	III											
<b>Enclosure rating</b>	IP 67, IP 69K											
<b>Circuit protection<sup>9)</sup></b>	A, B, C											
<b>Ambient temperature <math>T_A</math><sup>10)</sup></b>	Operation - 40 ... + 60 °C											
	Storage - 40 ... + 75 °C											
<b>Weight</b>												
with connection cable 2 m/120 mm	Approx. 80 g											
with equipment plug M12/M8, 4-pin	Approx. 20 g											

1) Limit values  
 2) Must be within  $V_S$  tolerances  
 3) Without load  
 4) Average service life at room temperature 100,000 h at  $T_A = + 25 \text{ °C}$

5) At  $T_A = + 25 \text{ °C}$  and 100 mA output current  
 6) With resistive load  
 7) With light/dark ratio 1:1  
 8) Reference voltage 50 V

9) A = supply connections reverse polarity protected  
 B = outputs short-circuit protected  
 C = interference suppression  
 10) Do not bend below 0 °C

**Scanning range**

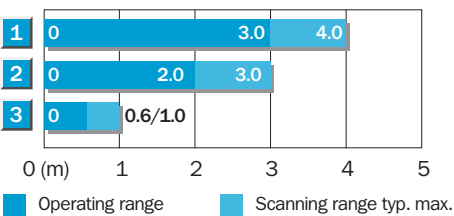

Reflector type	Operating range
1 PL 80 A	0 ... 3 m
2 PL 40 A	0 ... 2 m
3 Reflective tape Diamond Grade*	0 ... 0.6 m

\* 100 x 100 mm<sup>2</sup>

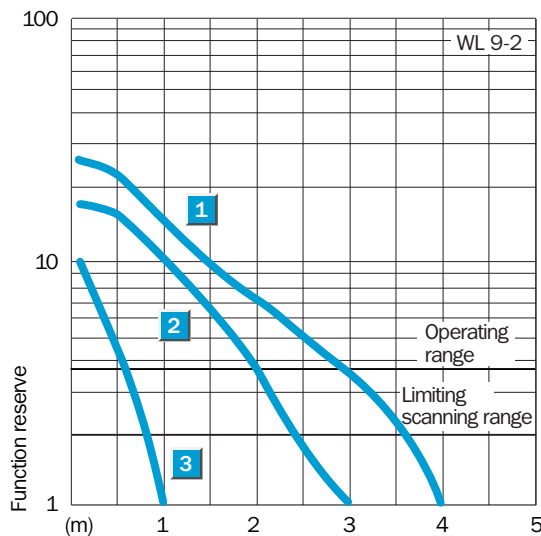

**Order information**

Type	Order no.
WL 9-2P 130	1 018 281
WL 9-2P 430	1 018 283
WL 9-2N 130	1 018 282
WL 9-2N 430	1 018 284
WL 9-2P 330	1 019 024
WL 9-2P 630	1 019 268
WL 9-2N 330	1 019 511

	<b>Scanning range</b>
	<b>0 ... 4 m</b>
Photoelectric reflex switches	

- Red-light emitter LED as alignment aid
- Switching frequency 800/s
- Outputs short-circuit protected
- Sensitivity adjustment using the Teach-in procedure
- Permissible ambient operating temperature  $-40\text{ °C} \dots +60\text{ °C}$

### Dimensional drawing

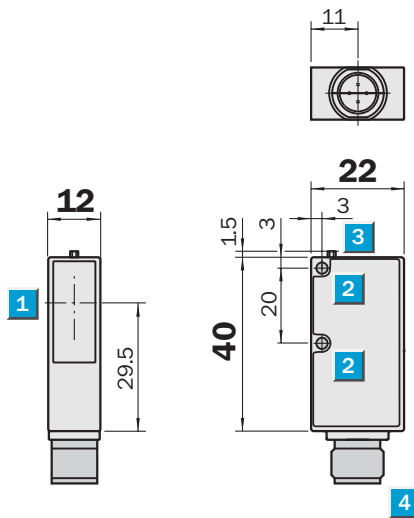

### Adjustments possible

WL 9-2P 131	WL 9-2P 331
WL 9-2P 431	WL 9-2P 631
WL 9-2N 131	
WL 9-2N 431	

- 1 Middle of optic axis
- 2 Mounting hole  $\varnothing 3.2\text{ mm}$
- 3 LED signal strength indicator
- 4 Plug M12 or M8, 4-pin, 2 m connection cable or 120 mm cable with plug M12, 4-pin
- 5 Teach-in button

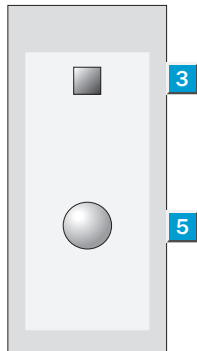

### Connection types

WL 9-2P 131	WL 9-2P 331
WL 9-2N 131	

WL 9-2P 331	WL 9-2P 631

WL 9-2P 431	WL 9-2N 431

WL 9-2P 631

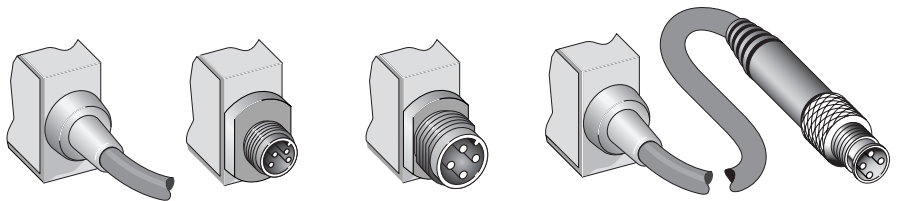

### See chapter Accessories

Cables and connectors
Mounting systems
Reflectors

### 4 x 0.14 mm<sup>2</sup>

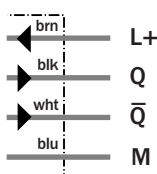

### 4-pin, M8

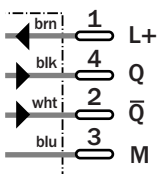

### 4-pin, M12

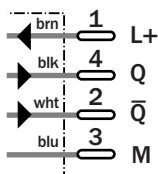

### 4-pin, M12 with 120 mm cable

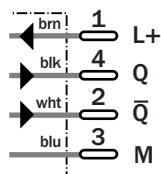

Technical data		WL 9-2	P 131	P 431	N 131	N 431	P 331	P 631				
<b>Scanning range typ. max./on reflector</b>	4 m/PL 80 A											
<b>Supply voltage <math>V_S</math><sup>1)</sup></b>	10 ... 30 V DC											
Ripple <sup>2)</sup>	$\leq 5 V_{pp}$											
Current consumption <sup>3)</sup>	$\leq 30 \text{ mA}$											
<b>Light source</b>	LED, visible red light <sup>4)</sup>											
Angle of dispersion	2.5°											
Light spot diameter	120 x 120 mm at 3 m											
<b>Switching outputs Q and <math>\bar{Q}</math></b>	PNP											
	NPN											
Signal voltage HIGH	$V_S - 2.9 \text{ V}$											
	$V_S$											
Signal voltage LOW <sup>5)</sup>	Approx. 0 V											
	$\leq 2.9 \text{ V}$											
<b>Output current <math>I_A</math> max.</b>	$\leq 100 \text{ mA}$											
<b>Response time<sup>6)</sup></b>	$\leq 625 \mu\text{s}$											
<b>Max. switching frequency<sup>7)</sup></b>	800/s											
<b>Connection types</b>	Connection cable, 2 m											
	Cable, 120 mm, with plug M12, 4-pin											
	Plug M12, 4-pin											
	Plug M8, 4-pin											
<b>VDE protection class M12<sup>8)</sup></b>	<input type="checkbox"/>											
<b>VDE protection class M8</b>	III											
<b>Enclosure rating</b>	IP 67, IP 69K											
<b>Circuit protection<sup>9)</sup></b>	A, B, C											
<b>Ambient temperature <math>T_A</math><sup>10)</sup></b>	Operation - 40 ... + 60 °C											
	Storage - 40 ... + 75 °C											
<b>Weight</b>												
with connection cable 2 m/120 mm	Approx. 80 g											
with equipment plug M12/M8, 4-pin	Approx. 20 g											

1) Limit values  
 2) Must be within  $V_S$  tolerances  
 3) Without load  
 4) Average service life at room temperature 100,000 h at  $T_A = + 25 \text{ °C}$   
 5) At  $T_A = + 25 \text{ °C}$  and 100 mA output current  
 6) With resistive load  
 7) With light/dark ratio 1:1  
 8) Reference voltage 50 V  
 9) A = supply connections reverse polarity protected  
 B = outputs short-circuit protected  
 C = interference suppression  
 10) Do not bend below 0 °C

**Teach-in function**

- **Programming via Teach-in button.**
- **Simple programming:**  
 Position reflector in the beam and push the button:  
 finished;  
 LED confirms the Teach-in procedure.
- **Teach-in values can be stored.**
- **Two operating modes:**  
**Default setting:** short Teach-in time (< 8 s);  
 for standard applications;  
 approx. double reserve via switching threshold;  
 LED lights continuously.  
**Precise setting:** long Teach-in time (> 8 s);  
 for precise applications;  
 small switching hysteresis;  
 LED blinks.

**Scanning range**

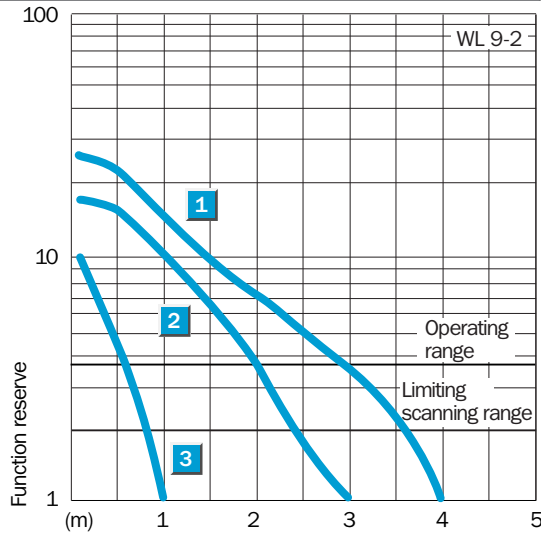
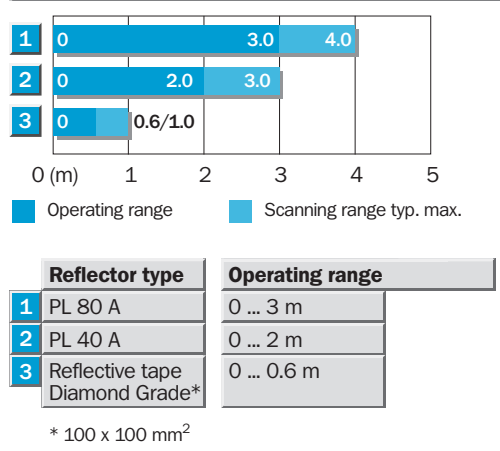

**Order information**

Type	Order no.
WL 9-2P 131	1 018 285
WL 9-2P 431	1 018 287
WL 9-2N 131	1 018 286
WL 9-2N 431	1 018 288
WL 9-2P 331	1 019 025
WL 9-2P 631	1 019 269

**Scanning range**  
**60 ... 4000 mm**

Photoelectric reflex switches

- Red-light emitter LED as alignment aid
- Switching frequency 800/s
- Outputs short-circuit protected
- Sensitivity adjustment using the Teach-in procedure
- Without polarisation filter
- Permissible ambient operating temperature -40 °C ... +60 °C

**Dimensional drawing**

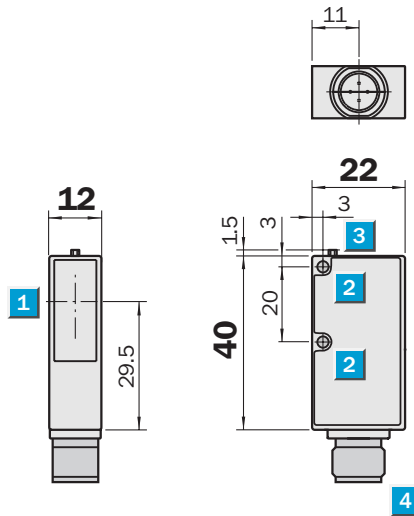

**Adjustments possible**

WL 9-2P481

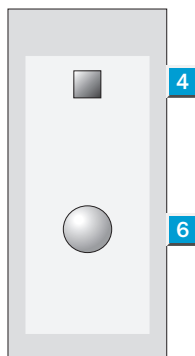

- 1 Axis of receiver optics
- 2 Axis of sender optics
- 3 Mounting hole  $\varnothing$  3.2 mm
- 4 LED signal strength indicator
- 5 Plug M12, 4-pin
- 6 Teach-in button

**Connection types**

WL 9-2P481

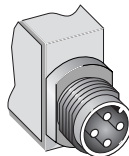

4-pin, M12

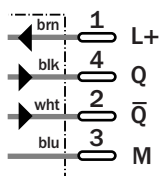

<b>See chapter Accessories</b>
Cables and connectors
Mounting systems
Reflectors

Technical data		WL 9-2	P481									
<b>Scanning range/on reflector</b>		4 m/PL 80 A										
		1 m/reflective tape										
<b>Light source</b> <sup>1)</sup>		LED, red light										
Light spot diameter		10 mm at a distance of 200 mm										
<b>Teach-in function</b>												
<b>Supply voltage</b> $V_S$ <sup>2)</sup>		10 ... 30 V DC										
Ripple <sup>3)</sup>		< 5 V <sub>pp</sub>										
Current consumption <sup>4)</sup>		< 30 mA										
<b>Switching outputs</b>		PNP, Q and $\bar{Q}$										
Output current $I_A$ max.		< 100 mA										
Response time <sup>5)</sup>		< 625 $\mu$ s										
Switching frequency max. <sup>6)</sup>		800/s										
<b>Connection technology</b>		Plug M12, 4-pin										
<b>VDE protection class</b> <sup>7)</sup>		II										
<b>Protection circuits</b> <sup>8)</sup>		A, B, C										
<b>Protection type</b>		IP 67, IP 69K										
<b>Ambient temperature</b> <sup>9)</sup>	Operation	-40 ... +60 °C										
	Storage	-40 ... +75 °C										
<b>Weight</b> with plug		Approx.. 120 g										
<b>Housing material</b>		Plastic, ABS										

<sup>1)</sup> Average service life at room temperature 100,000 h at  $T_U = +25$  °C  
<sup>2)</sup> Limit values  
<sup>3)</sup> Must be within  $V_S$  tolerances

<sup>4)</sup> Without load  
<sup>5)</sup> With resistive load  
<sup>6)</sup> With light/dark ratio 1:1  
<sup>7)</sup> Withstand voltage 50 V DC

<sup>8)</sup> A = supply connections reverse polarity protected  
 B = outputs short-circuit protected  
 C = interference suppression  
<sup>9)</sup> Do not distort cable below 0 °C

Teach-in function		Order information	
<ul style="list-style-type: none"> <li>■ <b>Programming via Teach-in button.</b></li> <li>■ <b>Simple programming:</b> Position object in the beam and push the button: finished; LED confirms the teach-in procedure.</li> <li>■ <b>Teach-in values can be stored.</b></li> </ul>	<ul style="list-style-type: none"> <li>■ <b>Two operating modes:</b>  <b>Default setting:</b> short Teach-in time (&lt; 8 s); for standard applications; approx. double reserve via switching threshold; LED lights continuously.  <b>Precise setting:</b> long Teach-in time (&gt; 8 s); for precise applications; small switching hysteresis; LED blinks.</li> </ul>	<b>Type</b>	<b>Order no.</b>
		WL 9-2P481	1 022 299

**Scanning range**  
**0 ... 0.4 m**  
 Photoelectric reflex switches

- LED light source, visible red light
- Switching frequency 800/s
- Outputs short-circuit protected
- Sensitivity adjustment using the Teach-in procedure
- Permissible ambient operating temperature  $-40\text{ °C} \dots +60\text{ °C}$

**Dimensional drawing**

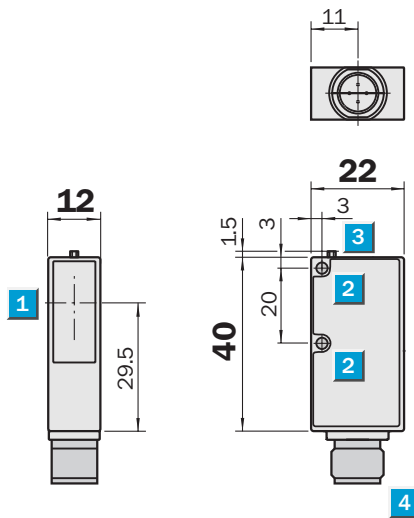

**Adjustments possible**

WL 9-2P 121	WL 9-2P 321
WL 9-2P 421	WL 9-2P 621
WL 9-2N 121	
WL 9-2N 421	

WL 9-2P 321	WL 9-2P 621
-------------	-------------

- 1 Middle of optic axis
- 2 Mounting hole  $\varnothing 3.2\text{ mm}$
- 3 LED signal strength indicator
- 4 Plug M12 or M8, 4-pin, 2 m connection cable or 120 mm cable with plug M12, 4-pin
- 5 Teach-in button

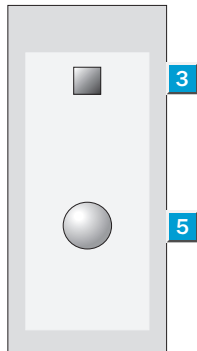

**Connection types**

WL 9-2P 121	WL 9-2P 321
WL 9-2N 121	

WL 9-2P 321	WL 9-2P 621
-------------	-------------

WL 9-2P 421	WL 9-2N 421
-------------	-------------

WL 9-2P 621
-------------

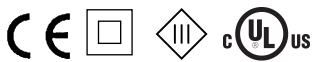
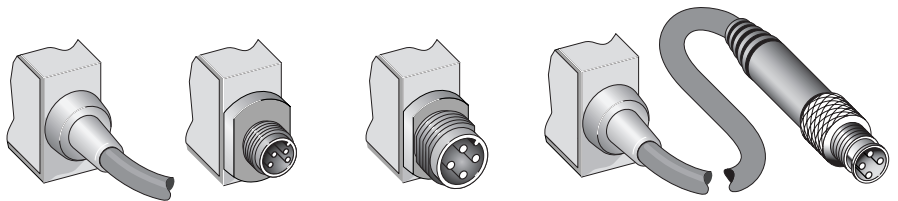

<b>See chapter Accessories</b>
Cables and connectors
Mounting systems
Reflectors

**4 x 0.14 mm<sup>2</sup>**

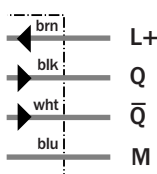

**4-pin, M8**

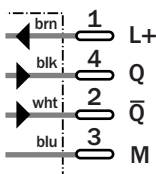

**4-pin, M12**

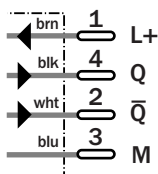

**4-pin, M12 with 120 mm cable**

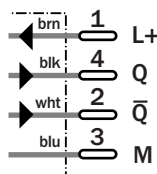

Technical data		WL 9-2	P 121	P 421	N 121	N 421	P 321	P 621				
<b>Scanning range typ. max./on reflector</b>	0.4 m/PL 80 A											
<b>Supply voltage <math>V_S</math><sup>1)</sup></b>	10 ... 30 V DC											
Ripple <sup>2)</sup>	$\leq 5 V_{pp}$											
Current consumption <sup>3)</sup>	$\leq 30$ mA											
<b>Light source</b>	LED, visible red light <sup>4)</sup>											
Light spot diameter	1.5 x 1.5 mm at 35 mm											
<b>Switching outputs Q and <math>\bar{Q}</math></b>	PNP											
	NPN											
Signal voltage HIGH	$V_S - 2.9$ V											
	$V_S$											
Signal voltage LOW <sup>5)</sup>	Approx. 0 V											
	$\leq 2.9$ V											
<b>Output current <math>I_A</math> max.</b>	$\leq 100$ mA											
<b>Response time<sup>6)</sup></b>	$\leq 625$ $\mu$ s											
<b>Max. switching frequency<sup>7)</sup></b>	800/s											
<b>Connection types</b>	Connection cable, 2 m											
	Cable, 120 mm, with plug M12, 4-pin											
	Plug M12, 4-pin											
	Plug M8, 4-pin											
<b>VDE protection class M12<sup>8)</sup></b>	<input type="checkbox"/>											
<b>VDE protection class M8</b>	III											
<b>Enclosure rating</b>	IP 67, IP 69K											
<b>Circuit protection<sup>9)</sup></b>	A, B, C											
<b>Ambient temperature <math>T_A</math><sup>10)</sup></b>	Operation - 40 ... + 60 °C											
	Storage - 40 ... + 75 °C											
<b>Weight</b>												
with connection cable 2 m/120 mm	Approx. 80 g											
with equipment plug M12/M8, 4-pin	Approx. 20 g											

- 1) Limit values
- 2) Must be within  $V_S$  tolerances
- 3) Without load
- 4) Average service life at room temperature 100,000 h at  $T_A = + 25$  °C
- 5) At  $T_A = + 25$  °C and 100 mA output current
- 6) With resistive load
- 7) With light/dark ratio 1:1
- 8) Reference voltage 50 V
- 9) A = supply connections reverse polarity protected  
B = outputs short-circuit protected  
C = interference suppression
- 10) Do not bend below 0 °C

**Teach-in function**

- **Programming via Teach-in button.**
- **Simple programming:**  
Position reflector in the beam and push the button: finished;  
LED confirms the Teach-in procedure.
- **Teach-in values can be stored.**
- **Two operating modes:**  
**Default setting:** short Teach-in time (< 8 s);  
for standard applications;  
approx. double reserve via switching threshold;  
LED lights continuously.  
**Precise setting:** long Teach-in time (> 8 s);  
for precise applications;  
small switching hysteresis;  
LED blinks.

**Scanning range**

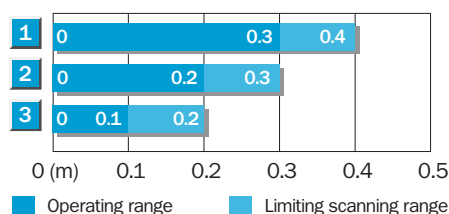

Reflector type	Operating range
1 PL 80 A	0 ... 0.3 m
2 PL 40 A	0 ... 0.2 m
3 Reflective tape Diamond Grade*	0 ... 0.1 m

\* 100 x 100 mm<sup>2</sup>

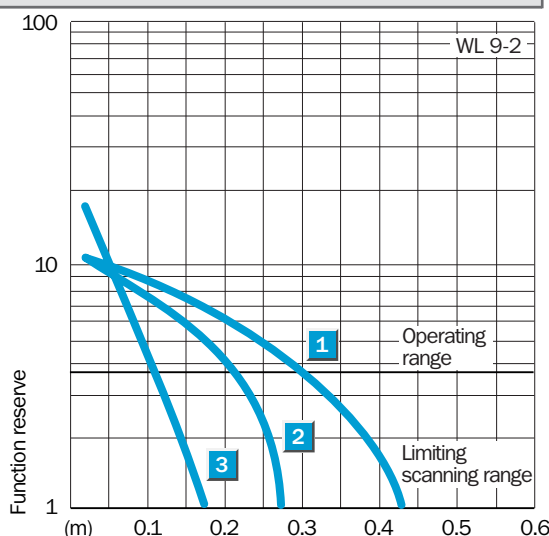

**Order information**

Type	Order no.
WL 9-2P 121	1 018 289
WL 9-2P 421	1 018 291
WL 9-2N 121	1 018 290
WL 9-2N 421	1 018 292
WL 9-2P 321	1 019 270
WL 9-2P 621	1 019 271



**Scanning range**  
7 m

Through-beam photoelectric switches

- Red-light emitter LED as alignment aid
- Switching frequency 200/s
- Outputs short-circuit protected
- Test input
- Permissible ambient operating temperature -40 °C ... +60 °C

## Dimensional drawing

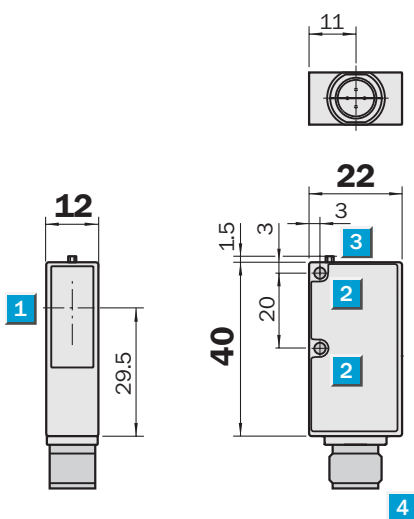

### No setting options

WS/WE 9-2P130	WS/WE 9-2P330
WS/WE 9-2P430	WS/WE 9-2P630
WS/WE 9-2N130	
WS/WE 9-2N430	

- 1 Middle of optic axis
- 2 Mounting hole Ø 3.2 mm
- 3 LED signal strength indicator
- 4 Plug M12 or M8, 4-pin, 2 m connection cable or 120 mm cable with plug M12, 4-pin

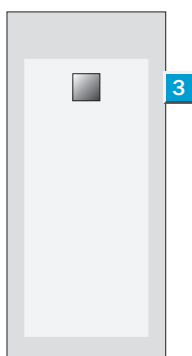

### Connection types

WS/WE 9-2P 130	WS/WE 9-2P 330	WS/WE 9-2P 430	WS/WE 9-2P 630
WS/WE 9-2N 130		WS/WE 9-2N 430	

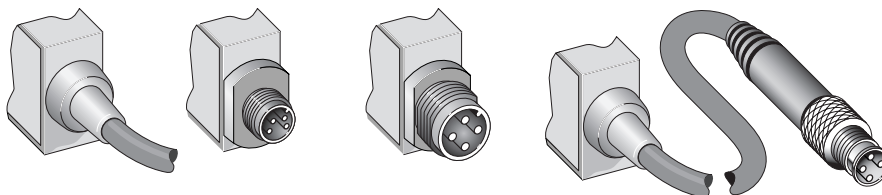

4 x 0.14 mm<sup>2</sup>

4-pin, M8

4-pin, M12

4-pin, M12 with 120 mm cable

### See chapter Accessories

- Cables and connectors
- Mounting systems

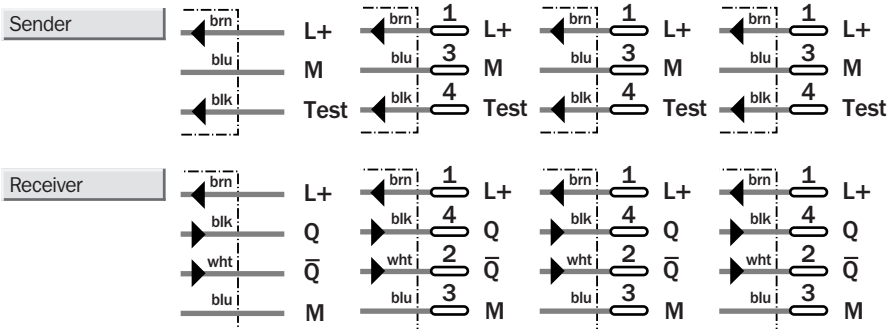

Technical data		WS/WE 9-2	P 130	P 430	N 130	N 430	P 330	P 630				
<b>Scanning range typ. max.</b>	7 m											
<b>Suggested operating range</b>	5 m											
<b>Supply voltage <math>V_S</math><sup>1)</sup></b>	10 ... 30 V DC											
Ripple <sup>2)</sup>	$\leq 5 V_{pp}$											
Current consumption <sup>3)</sup>	$\leq 15 \text{ mA (WE); } \leq 60 \text{ mA (WS)}$											
<b>Light source</b>	LED, visible red light <sup>4)</sup>											
Angle of dispersion	2.5°											
Angle of reception	6°											
Light spot diameter	200 mm at a distance of 5 m											
<b>Switching outputs Q and <math>\bar{Q}</math></b>	PNP											
	NPN											
Signal voltage HIGH	$V_S - 2.9 \text{ V}$											
	$V_S$											
Signal voltage LOW <sup>5)</sup>	Approx. 0 V											
	$\leq 2.9 \text{ V}$											
<b>Output current <math>I_A</math> max.</b>	$\leq 100 \text{ mA}$											
<b>Response time<sup>6)</sup></b>	$\leq 2.5 \text{ ms}$											
<b>Max. switching frequency<sup>7)</sup></b>	200/s											
Test input TE	$V_S$ or unswitched, sender active											
	0 V, sender inactive											
<b>Connection types</b>	Connection cable, 2 m											
	Cable, 120 mm, with plug M12, 4-pin											
	Plug M12, 4-pin											
	Plug M8, 4-pin											
<b>VDE protection class M12<sup>8)</sup></b>	<input type="checkbox"/>											
<b>VDE protection class M8</b>	III											
<b>Enclosure rating</b>	IP 67, IP 69K											
<b>Circuit protection<sup>9)</sup></b>	A, B, C											
<b>Ambient temperature <math>T_A</math><sup>10)</sup></b>	Operation - 40 ... + 60 °C											
	Storage - 40 ... + 75 °C											
<b>Weight</b>												
with connection cable 2 m/120 mm	Approx. 80 g											
with equipment plug M12/M8, 4-pin	Approx. 20 g											

1) Limit values  
 2) Must be within  $V_S$  tolerances  
 3) Without load  
 4) Average service life at room temperature 100,000 h

5) At  $T_A = + 25 \text{ °C}$  and 100 mA output current  
 6) With resistive load  
 7) With light/dark ratio 1:1  
 8) Reference voltage 50 V

9) A = supply connections reverse polarity protected  
 B = outputs short-circuit protected  
 C = interference suppression  
 10) Do not bend below 0 °C

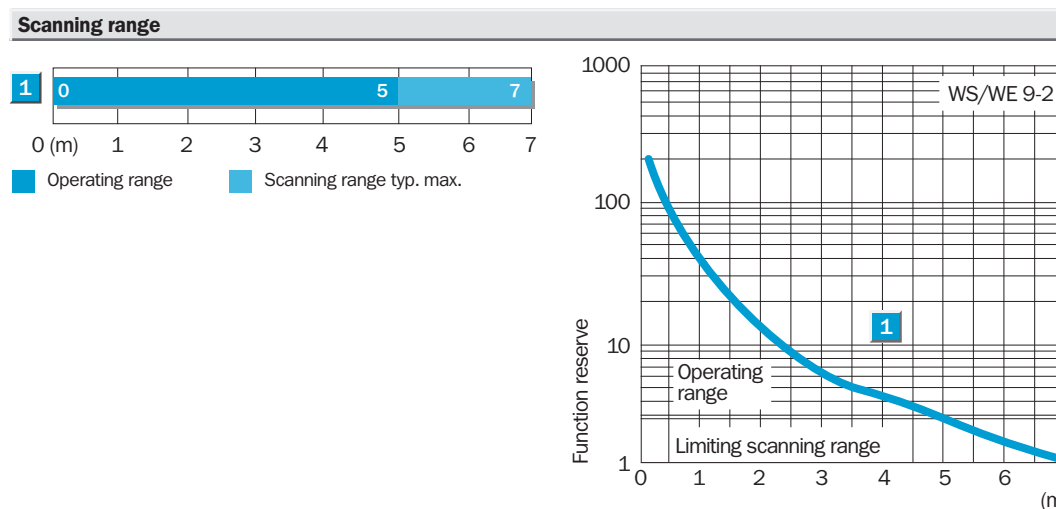

Order Information	
Type	Order no.
WS/WE 9-2P 130	1 019 259
WS/WE 9-2P 430	1 019 261
WS/WE 9-2N 130	1 019 260
WS/WE 9-2N 430	1 019 262
WS/WE 9-2P 330	1 019 383
WS/WE 9-2P 630	1 019 382